



# SERVICE MANUAL SSA100

## Stage Company SSA 100

High Efficiency Cinema Power Amplifier

Service Manual

April 2002  
Revision 2





# SERVICE MANUAL SSA100

## CONTENTS

<b>1</b>	<b>SAFETY AND WARRANTY</b>	<b>2</b>
	1.1 SAFETY	2
	1.2 WARRANTY	2
<b>2</b>	<b>TAKING THE SSA100 APART</b>	<b>4</b>
<b>3</b>	<b>BASIC OPERATION OF THE ELECTRONICS</b>	<b>5</b>
	3.1 INPUT AND PROTECION CIRCUITRY	5
	3.2 POWER SUPPLY CIRCUIT	5
	3.3 DRIVER BOARD	6
	3.4 POWER AMPLIFIER BOARD	7
<b>4</b>	<b>ADJUSTMENTS</b>	<b>7</b>
<b>5</b>	<b>FINAL TEST AFTER SERVICING</b>	<b>8</b>
<b>6</b>	<b>INSTALLING THE EFN BOARD</b>	<b>9</b>
<b>7</b>	<b>SPECIFICATIONS</b>	<b>10</b>
<b>8</b>	<b>PCB DRAWINGS AND CIRCUIT DIAGRAMS</b>	<b>11</b>

This manual contains confidential information. Any form of duplication is prohibited.



# SERVICE MANUAL SSA100

## 1 SAFETY AND WARRANTY

### 1.1 SAFETY

#### - Warning

Inside the SSA100, AC voltages up to 240V may be present!

#### - Connection to the mains voltage

The SSA100 chassis is connected to ground by the grounding conductor in the power cord. To avoid electrical shock, plug the power chord into a properly wired receptacle. When this ground connector is not present or interrupted, all accessible parts of the amplifier can cause an electrical shock.

#### - Fuses

To avoid fire hazard, only replace with fuses of the same type and value.

#### - Servicing

Do not perform internal service or adjustments unless there is another person present capable of rendering first aid and reanimation. Try to perform all service work with mains power off. Remove mains plug to be sure that there are no internal voltages present.

### 1.2 WARRANTY

#### - Summary

New Stage Accompany B.V. warrants to the original commercial purchaser of each new Stage Accompany product, from the date of purchase by the original purchaser until the end of the warranty period, that the product is free of defects in materials or workmanship.

#### - Warranty period

The warranty period on all Stage Accompany products is five years from the date of the first consumer purchase, with the exception off:

- all electrical products: three years from the date of the first consumer purchase;
- cone assemblies in the loudspeaker and diaphragms in the Compact Drivers: one year from the date of the first consumer purchase;
- movable parts, such as castors, locks, handles, hinges, fans etc. one year from the date of the first consumer purchase;
- computers and associated peripherals: six months from the date of the first consumer purchase.

#### - How to validate the warranty

To validate warranty, the purchaser must always keep the original receipt of purchase to establish the date of purchase.

#### - Items excluded from warranty

Appeal on warranty will be avoided in case:

- of defects caused by influence from the outside, accident, misuse, neglect or influence of water;
- the serial number on the warranty and/or product has been defaced, altered or removed;
- of damage due to shipment;
- of damage resulting from neglecting instructions listed in the user manual;
- of damage caused by incorrect, abnormal handling or abuse during delivery;
- the unit has been repaired (or shows signs of repair) by someone not authorised by New Stage Accompany B.V.;
- the original receipt of purchase cannot be presented whenever warranty service is required;
- the cause of damage is unknown.



## SERVICE MANUAL SSA100

### - What we will do

Shipment of the product to an authorised Stage Accompany service center is at the risk and responsibility of the customer. New Stage Accompany B.V. will pay for all labour and material expenses for all repairs covered by the warranty. New Stage Accompany B.V. will not pay for the costs of shipment to the service center or factory. However, New Stage Accompany B.V. will pay for the costs of return shipment to the customer if repairs are covered by warranty.

### - Caution

Warranty work can only be performed at authorised Stage Accompany service centres or at the Stage Accompany factory. Every repair or attempted repair by a non-authorised party will void the warranty.

New Stage Accompany B.V. reserves the right to alter specifications without prior notice.



stage accompany

## SERVICE MANUAL SSA100

### 2 TAKING THE SSA100 APART

The SSA100 can be taken apart in the following way:

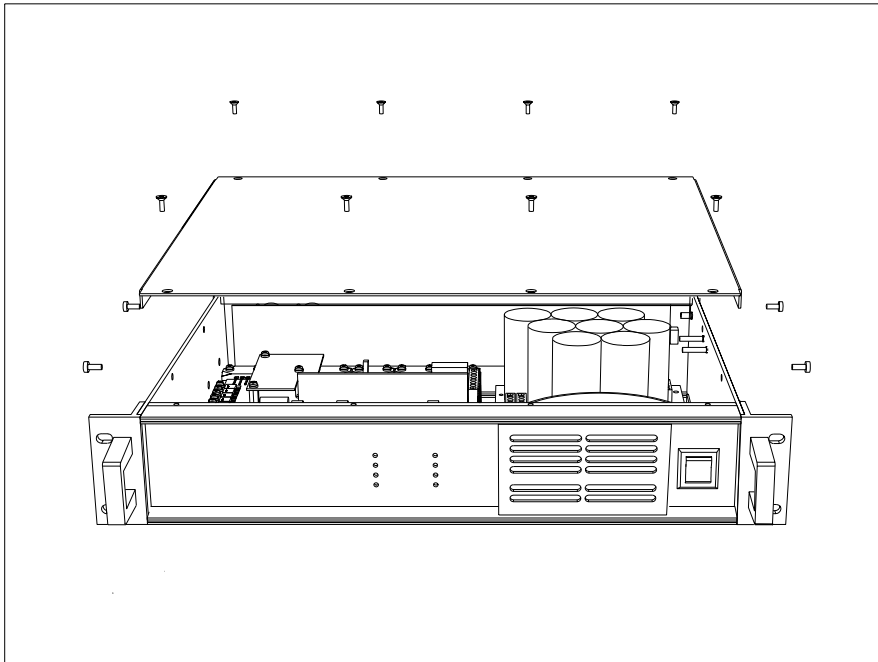

fig 2.1 Removing the lid.

Access to the electronics can be obtained by removing the top panel. Remove the eight screws at the top and the two screws on both the left and right side of the amplifier. Then carefully lift the top panel and disconnect the ground wire attached to the top panel at the inside of the amplifier.

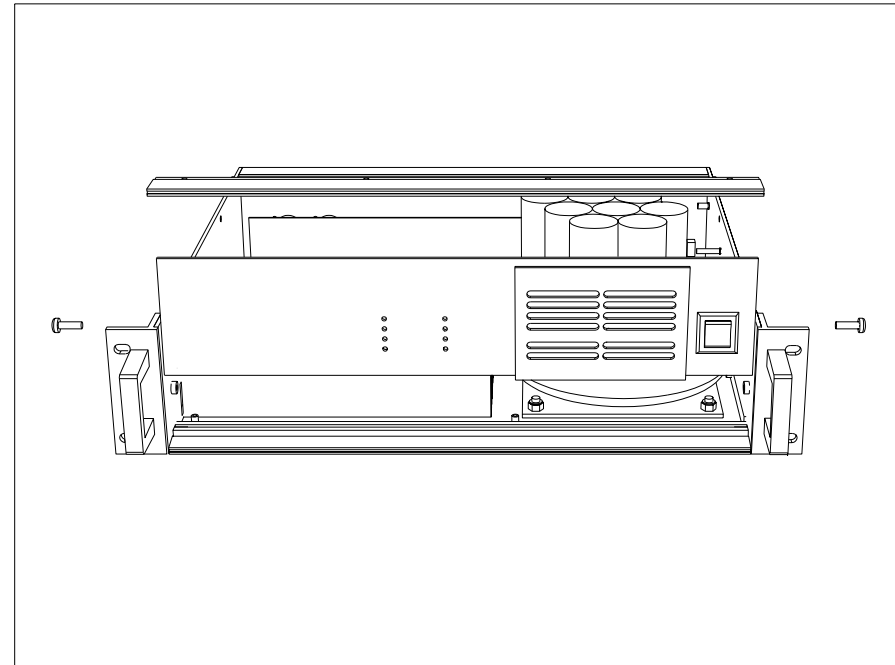

fig 2.2 Removing the front panel.

To obtain access to the frontboard, remove the bar on top of the frontpanel by removing one screw on both the left and right side of the amplifier. After removing two connectors from the front board (all connectors except for the fan connector) and disconnecting the mains switch, the frontpanel can be taken out.

To obtain access to the rearboard, the rearpanel can be removed in a similar way.



## 3 BASIC OPERATION OF THE ELECTRONICS

### 3.1 INPUT AND PROTECTION CIRCUITRY

The rear board and the front board contain the electronics for the input amplifier and protection circuitry

These boards contain:

- Signal present indication
- Amplifier level setting
- Thermal protection
- HF protection
- Fan speed control
- DC protection
- Clip indication
- DataPort interface

Input signals can be fed to the amplifier through the XLRs on the connector board or via the DataPort on the rearboard. The input amplifier is a differential line receiver. After the debalancing stage, the input signal can be attenuated by conductive plastic potentiometers. The signal is fed to a network that detects the presence of input signal. A LED on the frontpanel will light if the input signal exceeds  $-35$  dBu, regardless the setting of the input attenuators. The signal is also fed to the HF detection circuits. Both of these circuits are situated on the frontboard. For protection purposes, each channel can be muted by a relay (RL1 and RL2).

The thermal protection senses the temperature of each power amplifier as well as the mains transformer. IC4d on the frontboard determines the appropriate fan speed. IC2a and IC2b compare the measured temperatures to the programmed limits and activate the input mute relays and protect LED's if necessary. The amplifier limit is  $90$  °C and the transformer limit is  $100$  °C. The amplifiers are unmuted when the temperatures have dropped 5 degrees. A power amplifier thermal overload only mutes the related channel. A transformer thermal overload mutes both channels. Temperature information is send to the DataPort through IC3C and IC3D on the rearboard.

The DC protection senses the amplifier outputs for DC and very low frequency components. The output relay (located on the amplifier board) is muted when more than 3V DC (positive or negative) is detected. This circuit also provides a turn on delay for the output relays and a turn on delay for the input mute relays. When DC is detected, the protect LED will light on the amplifier's front panel. Comparators IC4C and IC4D form a turn-off delay for the input mute relais together with C24 and C25.

Clipping of the amplifiers is detected by the circuits around IC4a and IC4b on the rearboard. When the output of the amplifier is within the region of 0.5 dB to actual clipping, this is indicated by a LED on the frontpanel of the amplifier. Clip information is present on the DataPort pins 5 and 15.

### 3.2 POWER SUPPLY CIRCUIT

The power supply board contains all the electronics for rectifying and filtering 6 different supply voltages.  $\pm 86$  V and  $\pm 43$  V voltages feed the power amplifiers and  $\pm 26$  V supplies feed the front board and the DDC circuits. Inrush current reduction is obtained by NTCs SG1 and SG2. The SSA100 can internally be set to 110-120 V or 220-240 V operation. The voltage range is determined by CN11 and CN13. The correct settings are:

110-120 V : mains switch connector in CN11, jumper connector in CN13  
220-240 V : mains switch connector in CN13, jumper connector in CN11

Note that the  $\pm 26$  V voltages are protected by multifuses (F1 and F2). These devices normally have very low impedance. In case of a current overload the impedance rises to a high value, simulating a blown fuse. When this happens, turn off the amplifier and perform the needed repair. The multifuses reset automatically and do not need to be replaced.

## 3.3 DRIVER BOARD

The driver boards contain the preamplifiers of the SSA100. The basic electronics are shown in figure 3.1.

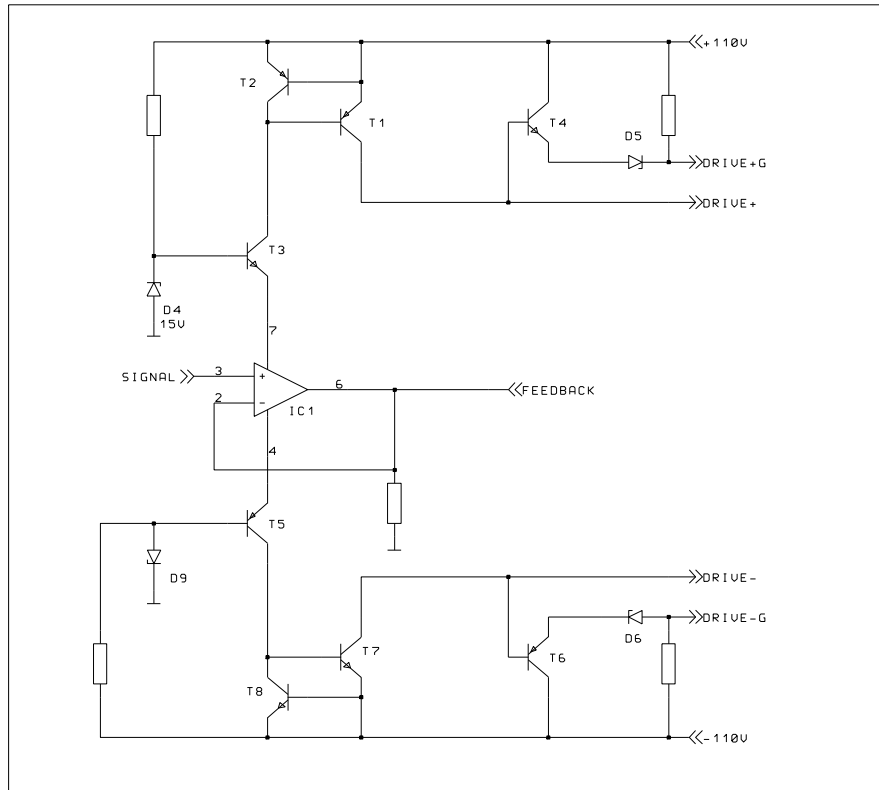

Figure 3.1 SSA100 preamplifier set-up.

The input signal is fed to a conventional opamp (IC1). The output current from IC1 is taken from its power supply pins and fed to the emitters of a pair of common base cascode transistors (T3 and T5) that provide regulated DC voltages for the opamp. The output currents from the input

buffer are fed to two current mirrors (T1/T2 and T7/T8), into the transimpedance gain stage. It is here that the high output voltage is generated. The half wave rectification action of IC1's output current causes the two current mirrors to receive complementary input currents. When IC1 is sourcing output current, it causes a corresponding increase in the current of the upper mirror and a decrease in that of the lower mirror. This forces the voltage at the output of the transimpedance stage to swing positive. For cases when IC1 is sinking current, exactly the opposite is true. Note that the quiescent supply current of IC1 serves to bias the two current mirrors that sit referenced to each power supply rail, thus providing an appropriate operating point for the transimpedance stage and bias voltage generator (both located on the poweramplifier board). Drive currents for the class G output power stage are supplied through T4 and T6. Zenerdiodes D5 and D6 are a constant voltage source of 6.2 volts that provide the necessary voltage gap for driving the class G current gain amplifier on the power amplifier board.

## 3.4 POWER AMPLIFIER BOARD

Figure 3.2 shows the basic set-up of the power amplifier.

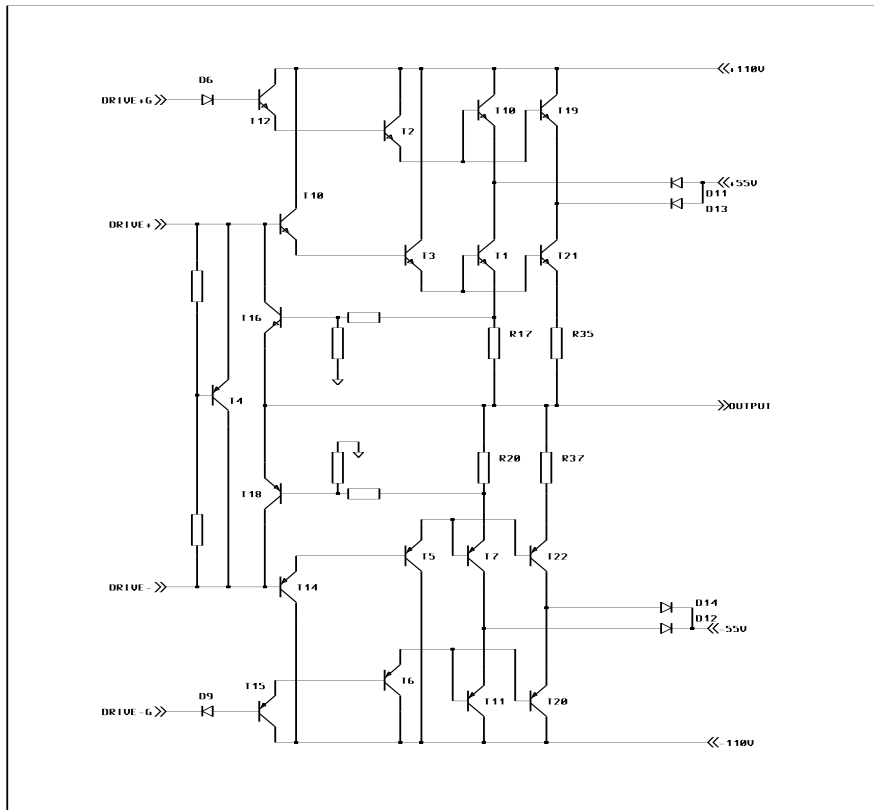

Figure 3.2 SSA100 power amplifier set-up.

The driver board circuit provides four signals, drive +, drive -, drive +g and drive -g. The positive drive current (drive +) is boosted by T13 and T3 and fed to the NPN power transistors T1 and T21. The negative drive current (drive -) is boosted by T14 and T5 and fed to the PNP power transistors T7 and T22. The positive class G drive current (drive +g) is boosted by T12

and T2 and fed to the NPN power transistors T10 and T19. The negative class G drive current (drive -g) is boosted by T15 and T6 and fed to the PNP power transistors T11 and T20. T4 is configured as a constant voltage source and provides the bias current for the amplifier output stage. The amplifier normally operates on the  $\pm 55$  V power supplies though diodes D11, D13, D12 and D14. The collectors of T1 and T21 have in this case a constant voltage of +43 V. When the output of the amplifier rises above +48 V the emitter voltages of T10 and T19 will rise linearly with the output voltage taking over the power supply from D11 and D13. Exactly the same is true for the negative side of the amplifier. Dynamic current limiting of the amplifier output stage is handled by T16 and T18. When the current drawn from the amplifier rises, the voltage across R17 and R20 rises too. At the moment that this voltage reaches 0.65 volts, T16 and T18 start conducting drive current away from the output transistors and thus limiting output current. Current limiting depends on the output voltage. At 0 V output the maximum current per transistor is 5.5 A rising to 12 A at 40 V. Overall feedback and DC stability of the amplifier is achieved by the DDC circuit build around opamp IC1.

## 4 ADJUSTMENTS

After repairs the amplifier's bias current should be checked and readjusted if necessary. The bias current for each transistor pair is approximately 50 mA ( $\pm 25$  %) at 40 °C. The bias current can be checked by measuring the voltage across one of the 0E33 emitter degradation resistors and can be adjusted with P1. Turning P1 clockwise will increase bias current. Adjust P1 for approximately 15 mV.





## 5 FINAL TEST AFTER SERVICING

For a final test of the amplifier a signal generator and a level/distortion analyser are needed. First check the amplifier's maximum power output. Connect 8 Ohm dummy loads to both outputs and apply a 1 kHz signal to both inputs. The output voltages should at least be 49 Vrms single channel, or 45 Vrms both channels driven (with a correct 230 V mains voltage).

Next check the frequency response. This should be done at an output level of approximately 10 Vrms and an 8 Ohm dummy on both outputs. The final result should be better than 10 Hz..60 kHz -3 dB.

Next check the total harmonic distortion. The final test specifications are: Uout = 28 Vrms into 8 or 4 Ohm: THD < 0.2 @10 Hz .. 20 kHz, measured in a 80 kHz bandwidth.

The total noise level of the amplifier should be approximately 110 dB(A) under 45 Vrms output level (-75 dBu). For this test the XLR input connectors are left open.

## 6 INSTALLING THE EFN BOARD

To install the 'EFN' board, remove the SSA100's top panel as is described in chapter 2. Figure 6.1 shows where to insert the EFN circuit board for channel 1. The EFN board 'clicks' into the connector on the amplifier board and does not need to be secured by any screws. To activate the EFN module, jumper J1 on the amplifier board needs to be placed in the position 'EQ CARD' otherwise the EFN modules are bypassed. The installation procedure of the channel 2 EFN module is identical to the installation of the channel 1 module.

For bridge mode operation **two** special bridge mode modules are needed. The standard EFN-DP protection boards are **not** suitable for bridge mode operation!

Attach the grounding wire to its connector attached to the underside of the lid and screw the lid back on. When removing the EFN module(s), move jumper J1 back to its original position, otherwise the signal path to the power amplifier is interrupted and the amplifier will not work!

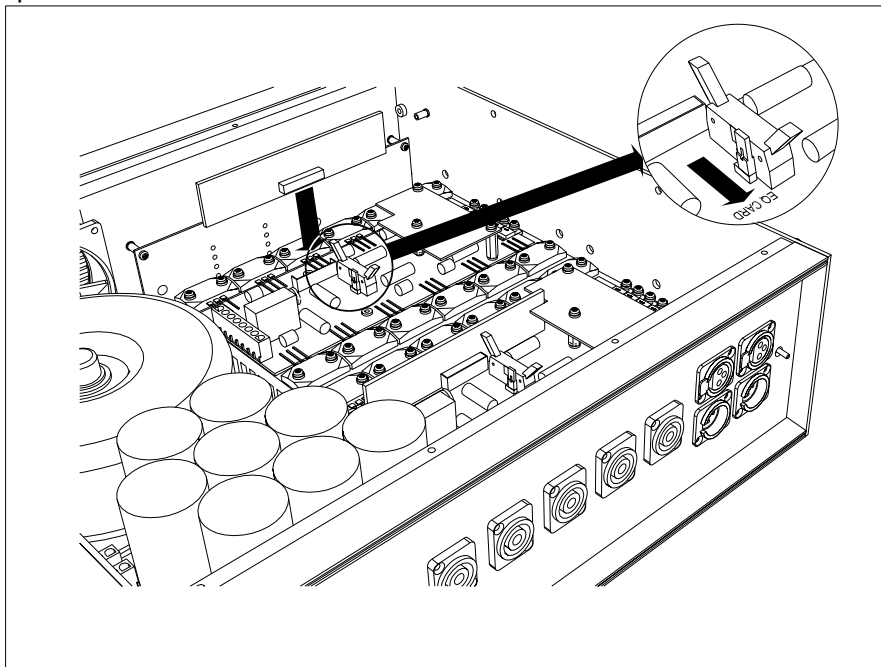

fig 6.1 Installing the EFN board for channel 1.



## SERVICE MANUAL SSA100

### 7 SPECIFICATIONS

Input sensitivity	: 1.0 Vrms (+2.5 dBu) for full RMS power into 4 Ohm
Maximum input level	: +20 dBu
Input impedance	: 20 kOhm balanced
Common mode rejection	: > 55 dB @ 1 kHz
Frequency range	: @ 50 W into 8 Ohm 10 Hz..20 kHz +0..-0.3 dB 10 Hz..70 kHz +0..-3 dB
Gain	: 32 dB (40x)
Channel separation	: > 75 dB @ 1kHz, 50 W into 8 Ohm > 55 dB @ 20 kHz, 50 W into 8 Ohm
Total harmonic distortion	: < 0.3 % @ 20 Hz..20 kHz, more than 2 Ohm load at all powers 1 dB below clipping < 0.01 % @ 1 kHz, 50 W into 8 Ohm < 0.1 % @ 20 kHz, 50 W into 8 Ohm
Intermodulation distortion	: @ 50 W into 8 Ohm < 0.07 % @ 200 Hz..10 kHz < 0.2 % @ 10 kHz..20 kHz
Signal to noise ratio	: > 115 dB A-weighted
Slew rate	: > 40 V/μs
Damping factor	: 10.000 @ 1 kHz, 8 Ohm
Output power	: RMS / Peak @ 1 kHz, 1 % THD 2 x 290 / 340 W @ 8 Ohm 2 x 425 / 535 W @ 4 Ohm 2 x 525 / 700 W @ 2 Ohm
Output power bridged	: RMS / Peak @ 1 kHz, 1 % THD 1 x 580 / 680 W @ 16 Ohm 1 x 850 / 1070 W @ 8 Ohm 1 x 1050 / 1400 W @ 4 Ohm
Mains supply voltage	: Stated at rear of amplifier

Power consumption	: 50 VA (standby) 700 VA 1/8 of maximum output power pink noise in 2 Ohm
Weight	: 17.7 kg, 39 lb
Housing	: 19 inch rack mount 2 HU, 410 mm (16.1 in) deep behind the mounting surface (without connectors).
Dimensions	: 88 x 482 x 415 mm (h x w x d) (3.5 x 19.0 x 16.3 in) (without connectors)





# SERVICE MANUAL SSA100

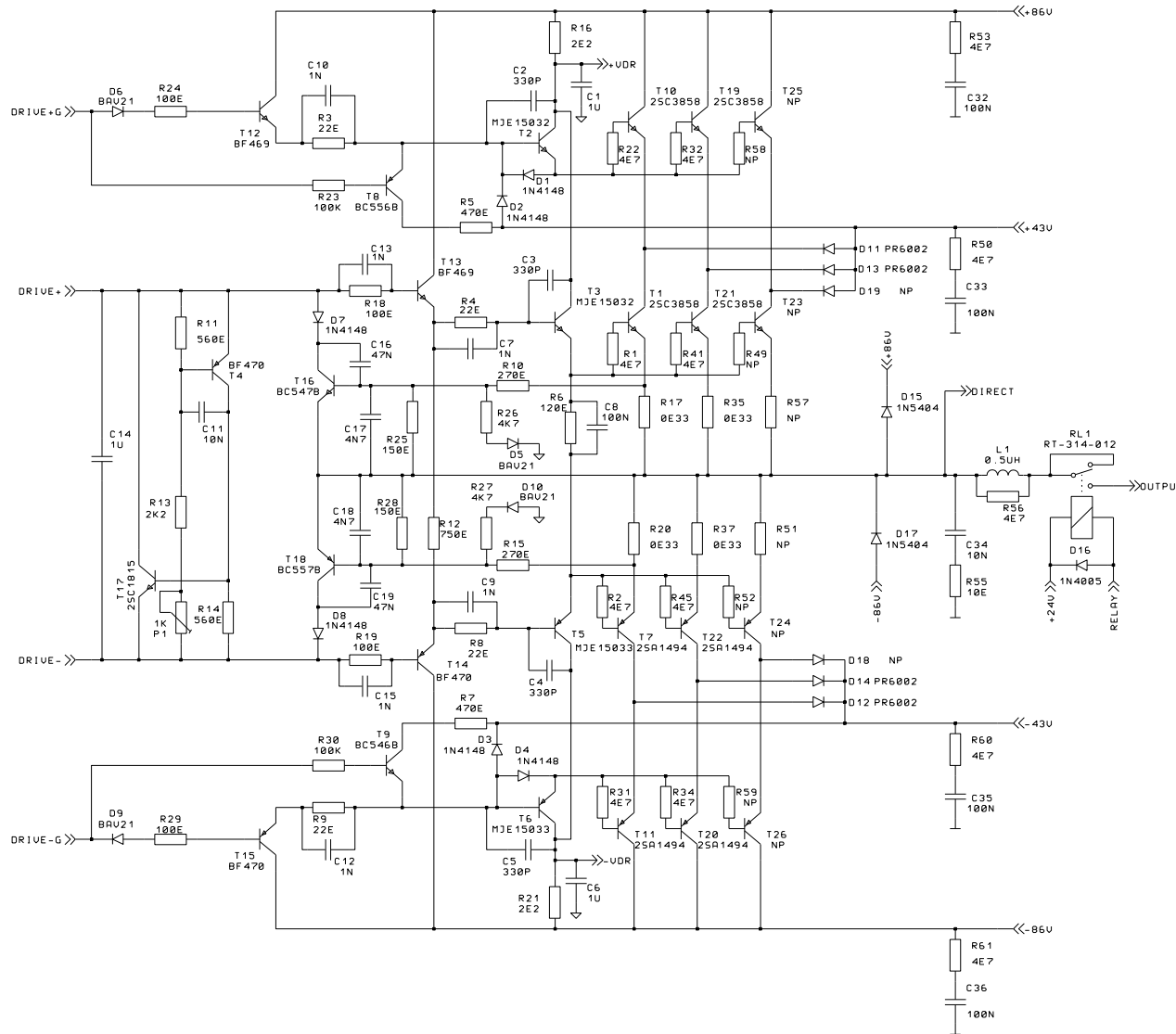



IC2 LM35  
 +15V  
 TEMP  
 PGND

IC3 LM35  
 +15V  
 TEMP  
 PGND

FOR CH1 BOARDS. IC3 NOT INSTALLED  
 FOR CH2 BOARDS. IC2 NOT INSTALLED

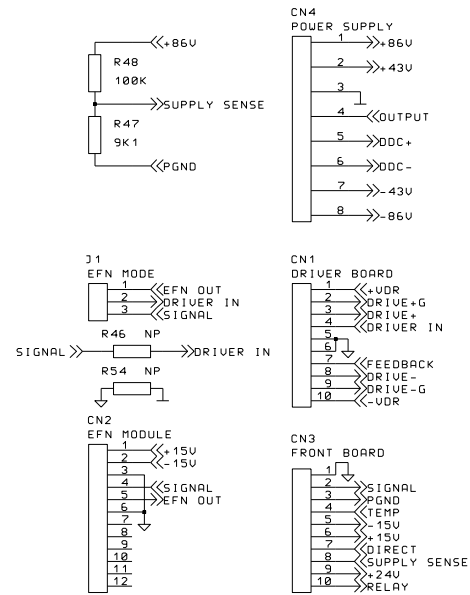
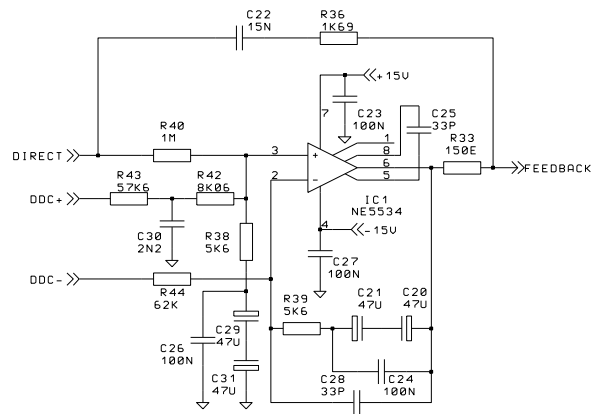
Stage Accompany bv Hoorn The Netherlands	
Project	: SSA100
Print	: Amplifier board
PCB no.	: 1085.2000/2
Date	: 19-02-2002
Drawn	: J.M. Fortanier
2 pages	Revision : 1



	Stage Accompany bv Hoorn The Netherlands	
	Project	: SSA100
	Print	: Amplifier board
	PCB no.	: 1085.2000/2
Date	: 19-02-2002	
Drawn	: J.M. Fortanier	
2 pages		Revision : 1

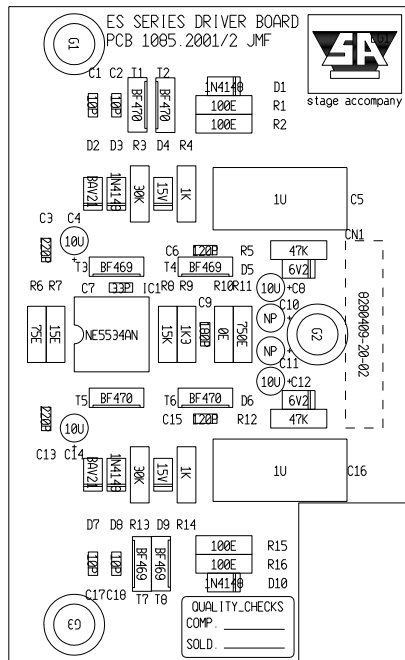



Stage Accompany bv  
Hoorn  
The Netherlands

Project : SSA100/200  
Print : Driver board  
PCB no. : 1085.2001/2  
Date : 02-11-2001  
Drawn : J.M. Fortanier

1 page

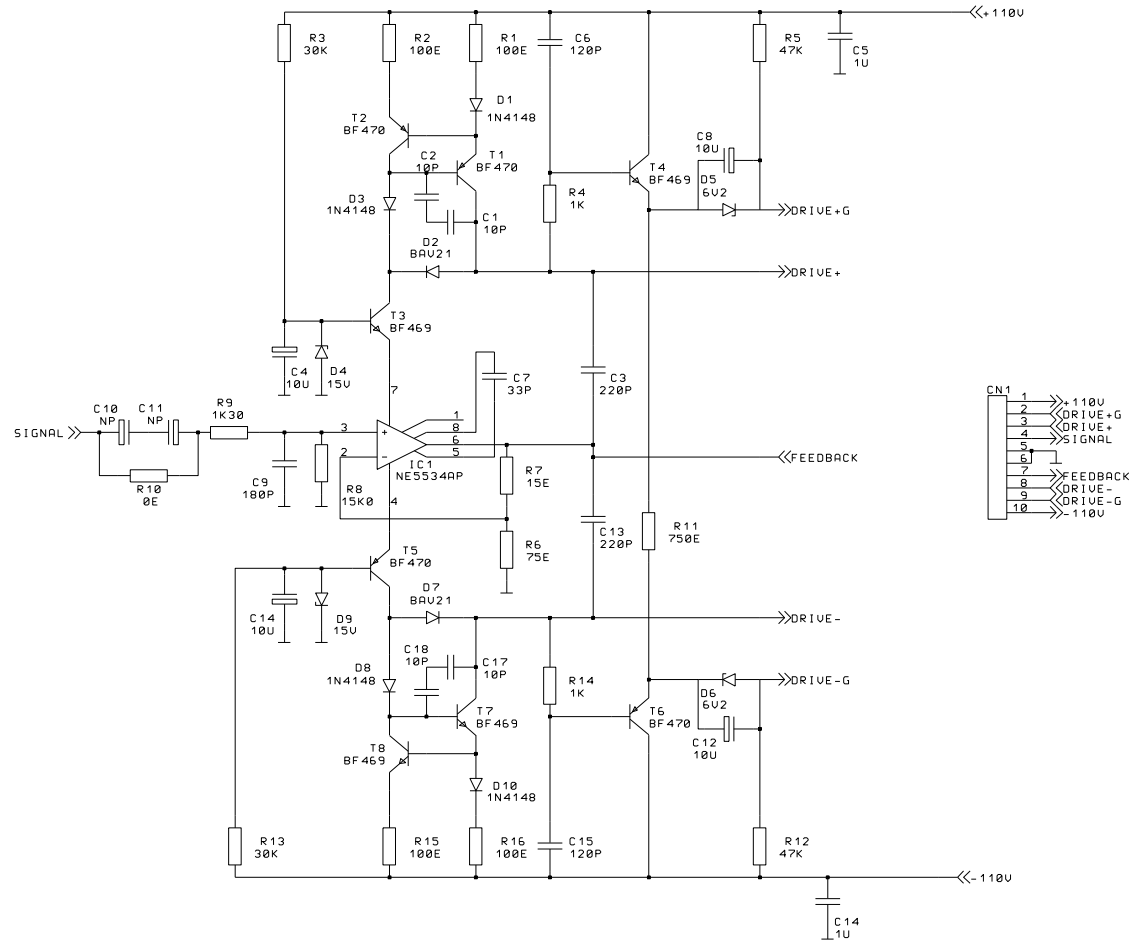
Revision : 0



	Stage Accompany bv Hoorn The Netherlands
	Project : SSA100/200 Print : Driver board PCB no. : 1085.2001/2 Date : 25-04-2002 Drawn : J.M. Fortanier
1 page	Revision : 0





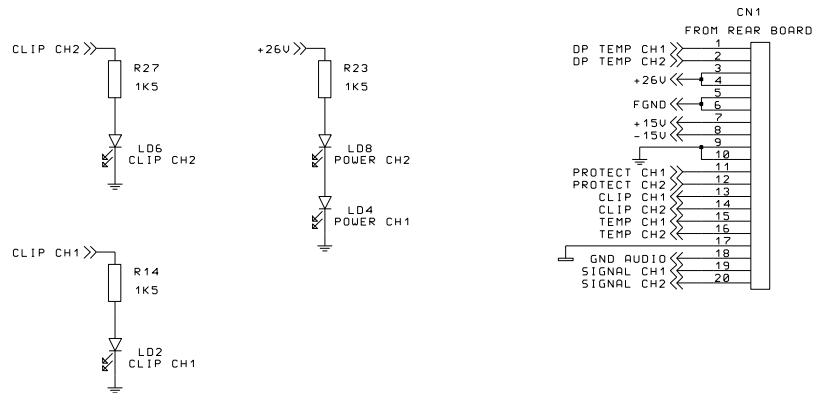
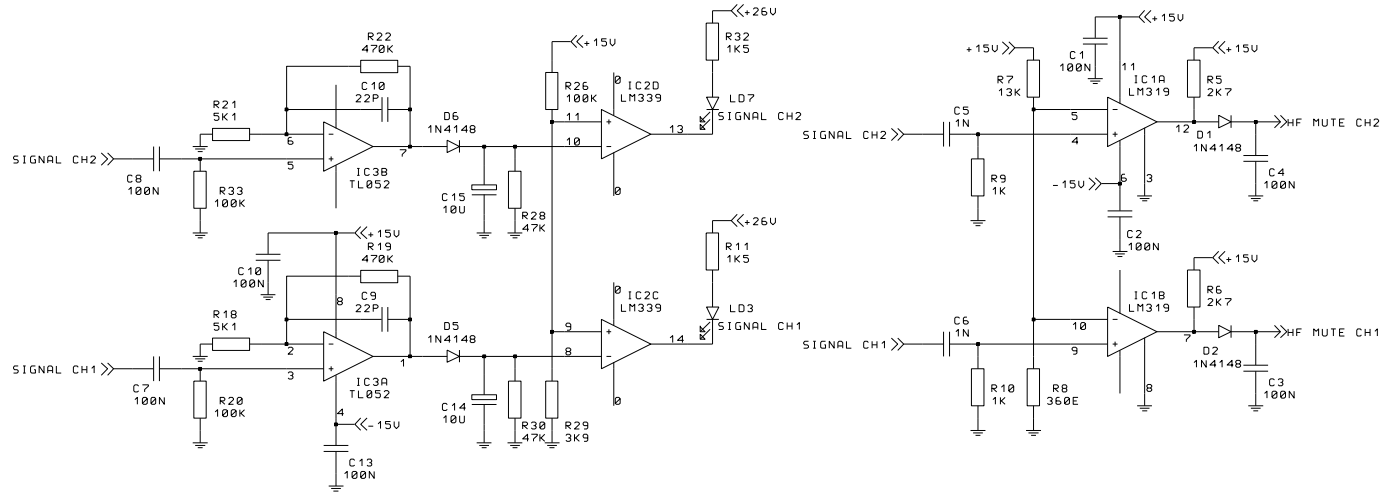

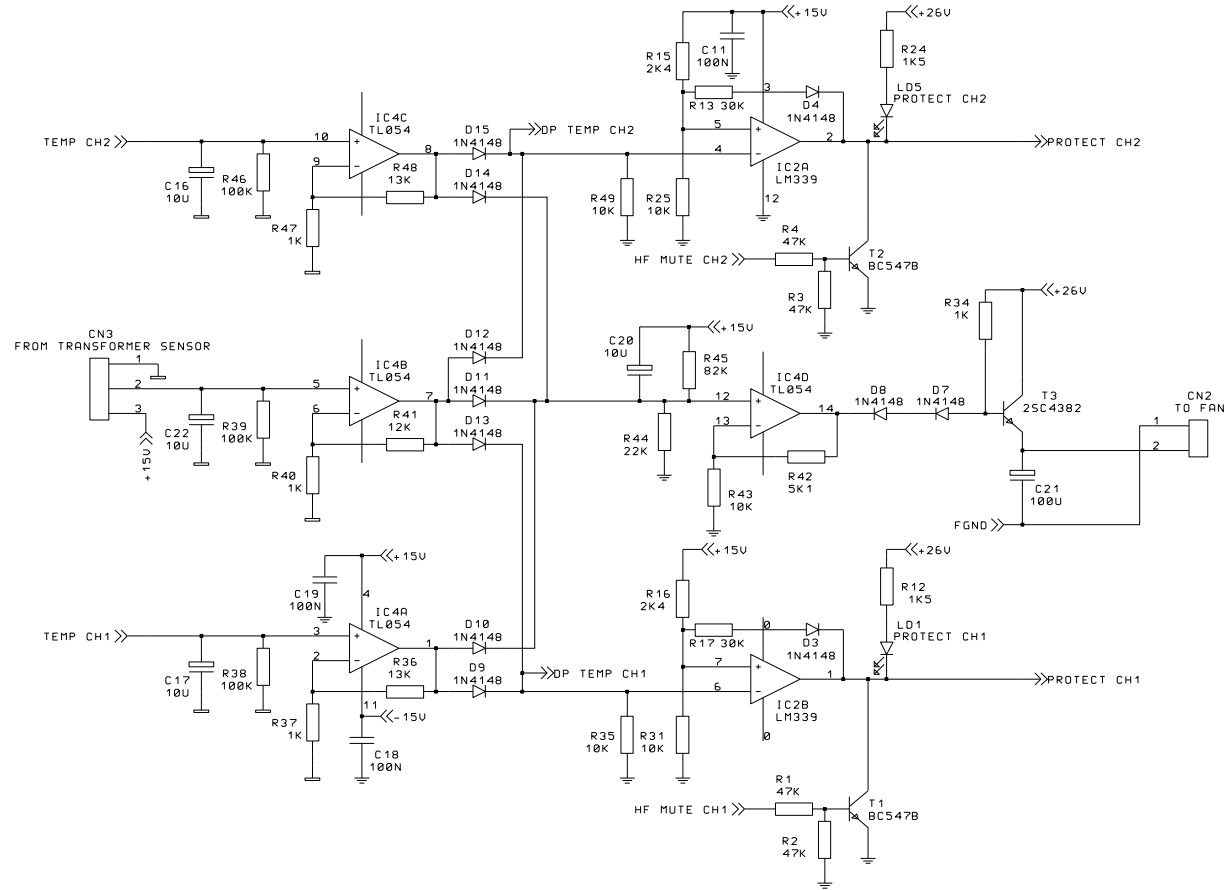

	Stage Accompany bv Hoorn The Netherlands
	Project : SSA100/SSA200 Print : Front board PCB no. : 1085.2002S/2 Date : 31-01-2002 Drawn : J.M. Fortanier
2 pages	Revision : 01

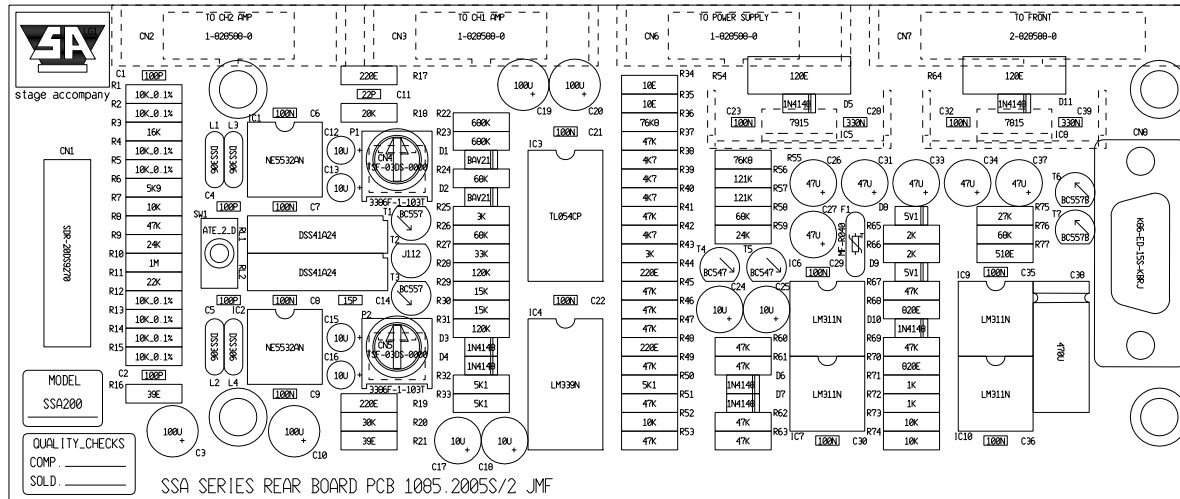

	Stage Accompany bv Hoorn The Netherlands
	Project : SSA100/SSA200
	Print : Front board
	PCB no. : 1085.2002S/2
Date : 31-01-2002	
Drawn : J.M. Fortanier	
2 pages	Revision : 01



 stage accompany	Stage Accompany bv Hoorn The Netherlands
	Project : SSA100/SSA200 Print : Rear board PCB no. : 1085.2005S/2 Date : 25-09-2001 Drawn : J.M. Fortanier
1 page	Revision : 0



# SERVICE MANUAL SSA100

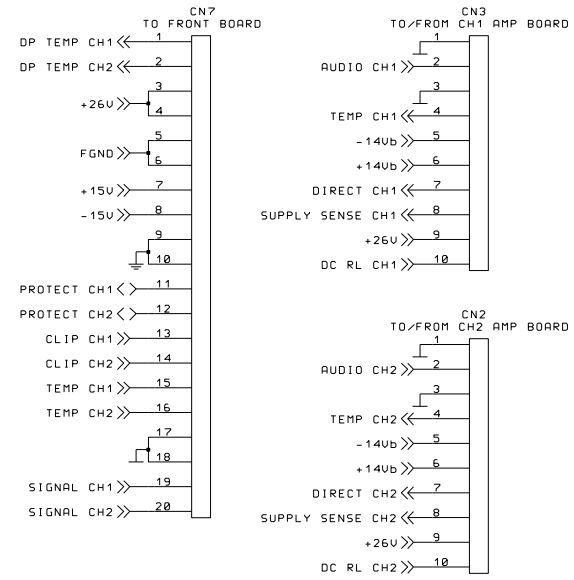
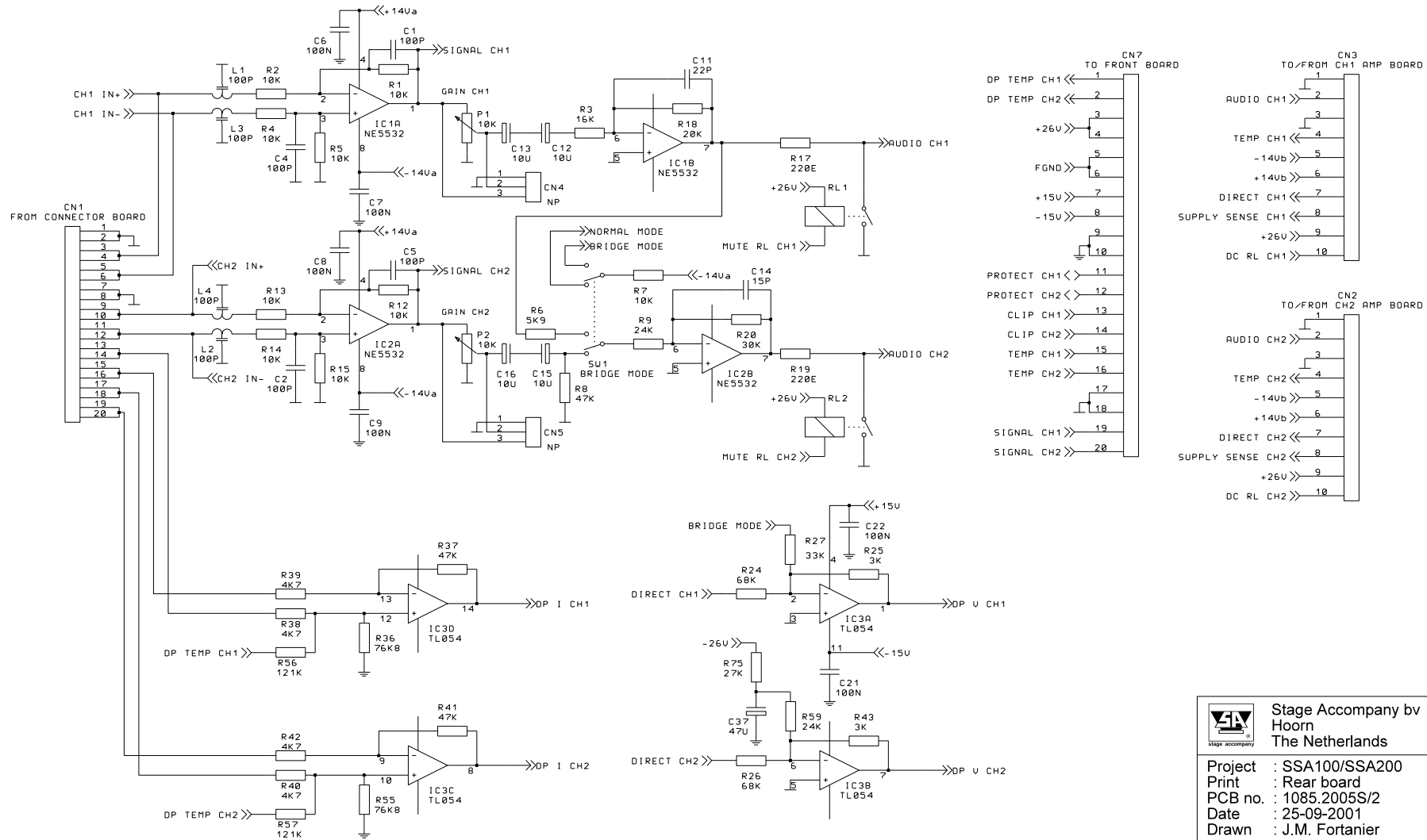

	Stage Accompany bv Hoorn The Netherlands
	Project : SSA100/SSA200 Print : Rear board PCB no. : 1085.2005S/2 Date : 25-09-2001 Drawn : J.M. Fortanier
	3 pages
	Revision : 0

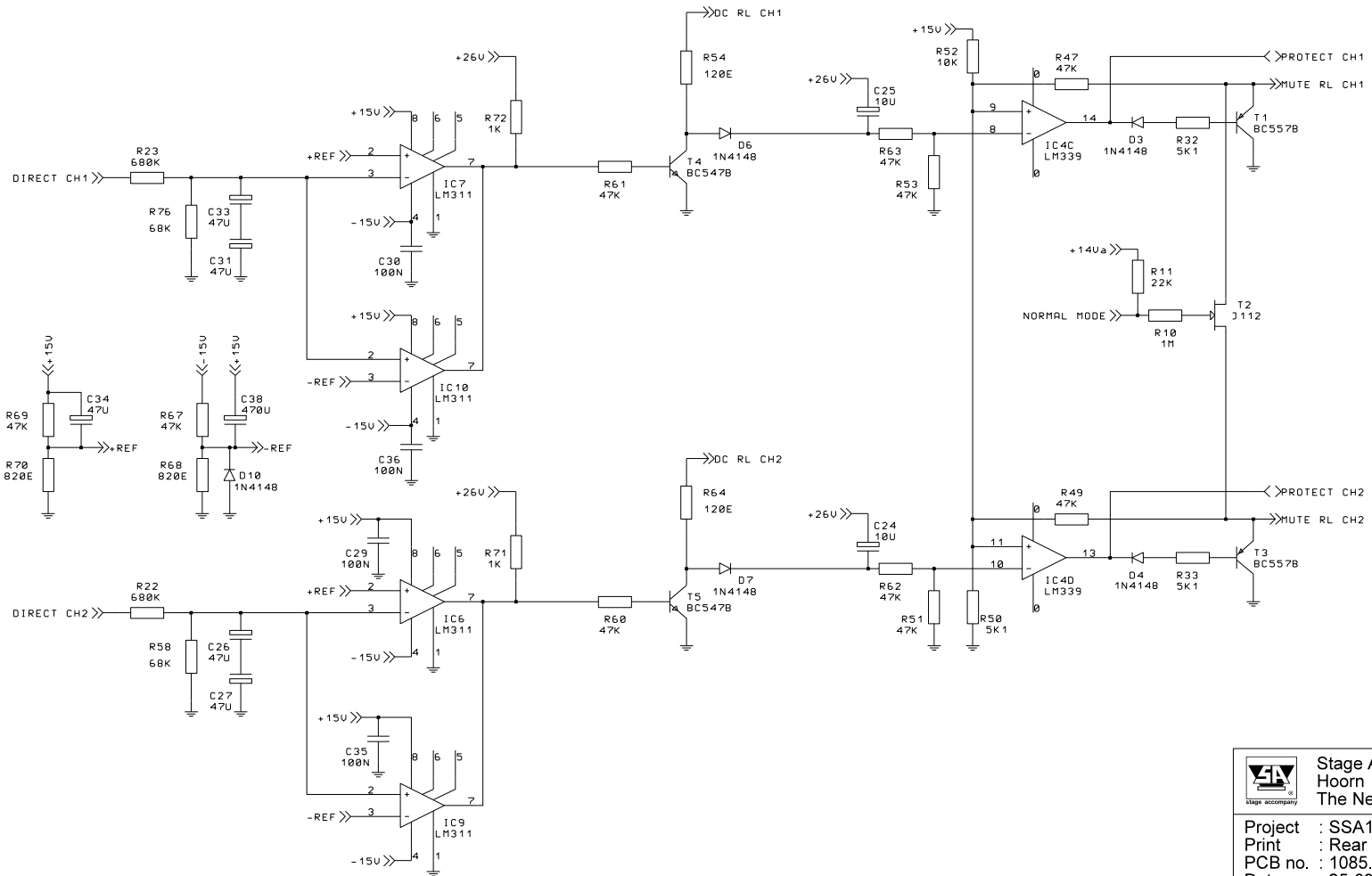

 Stage Accompany bv  
Hoorn  
The Netherlands

Project : SSA100/SSA200  
Print : Rear board  
PCB no. : 1085.2005S/2  
Date : 25-09-2001  
Drawn : J.M. Fortanier

3 pages

Revision : 0

# SERVICE MANUAL SSA100

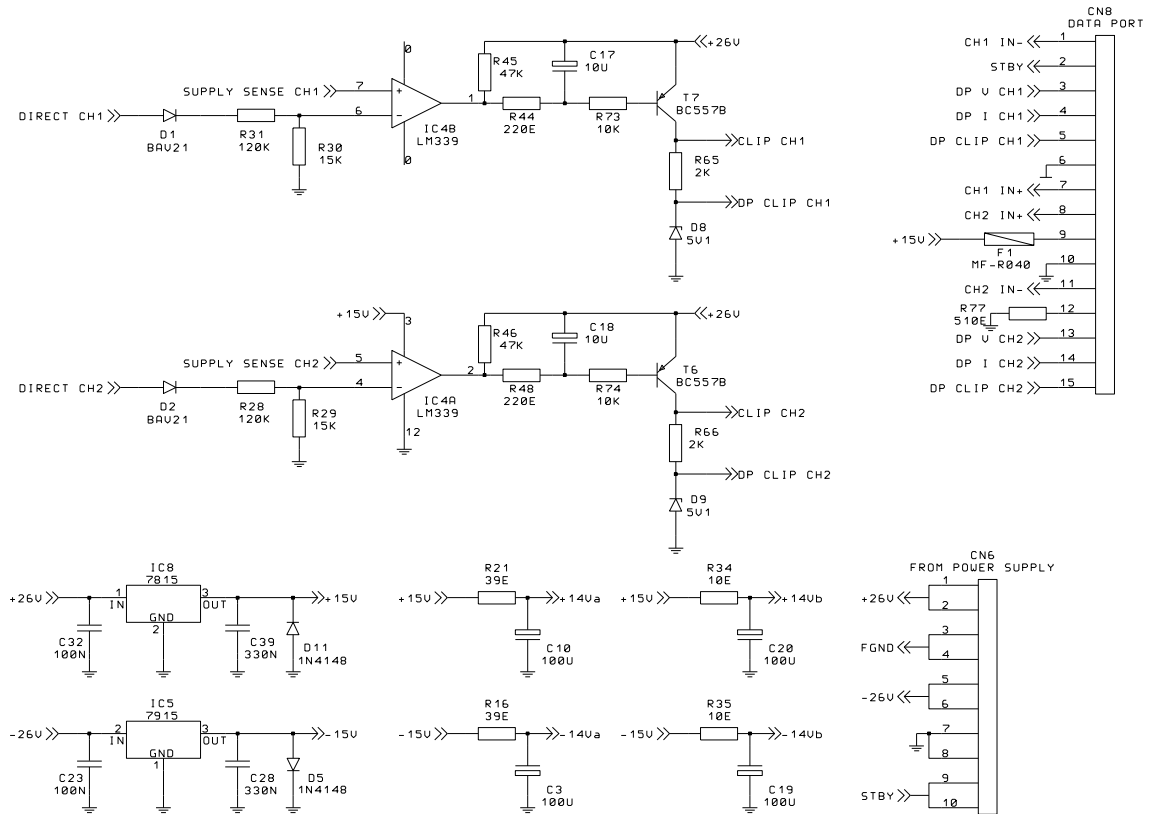

 Stage Accompany bv  
 Hoorn  
 The Netherlands  
 Project : SSA100/SSA200  
 Print : Rear board  
 PCB no. : 1085.2005S/2  
 Date : 25-09-2001  
 Drawn : J.M. Fortanier

3 pages      Revision : 0

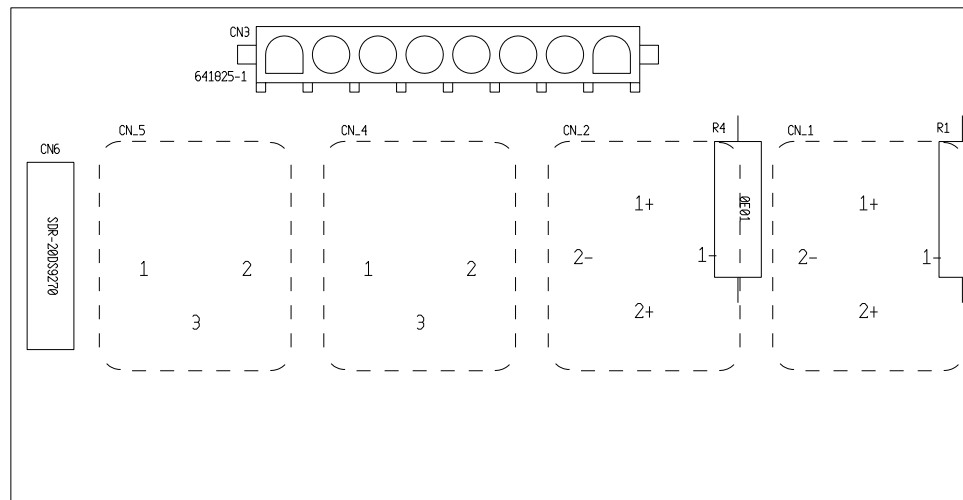
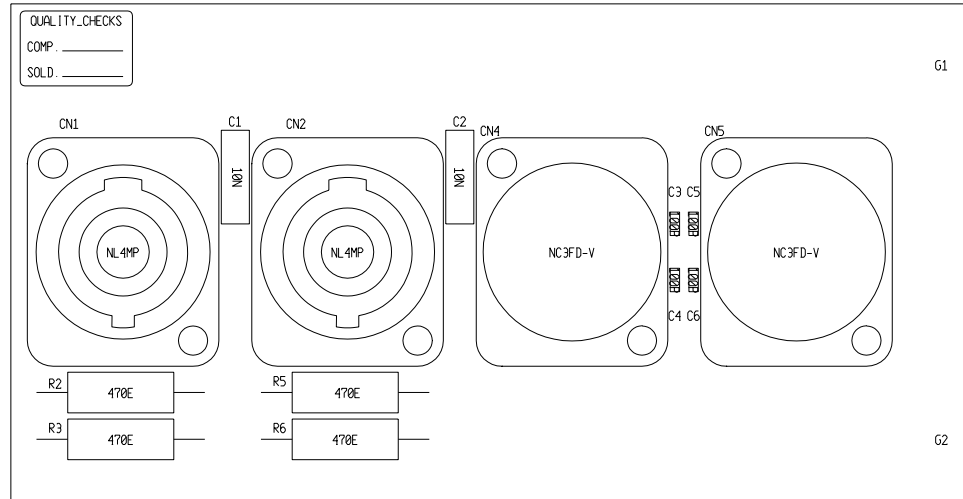

	Stage Accompany bv Hoorn The Netherlands
	Project : SSA100/SSA200 Print : Connector board PCB no. : 1085.2003S Date : 03-04-2001 Drawn : J.M. Fortanier
1 page	Revision : 0



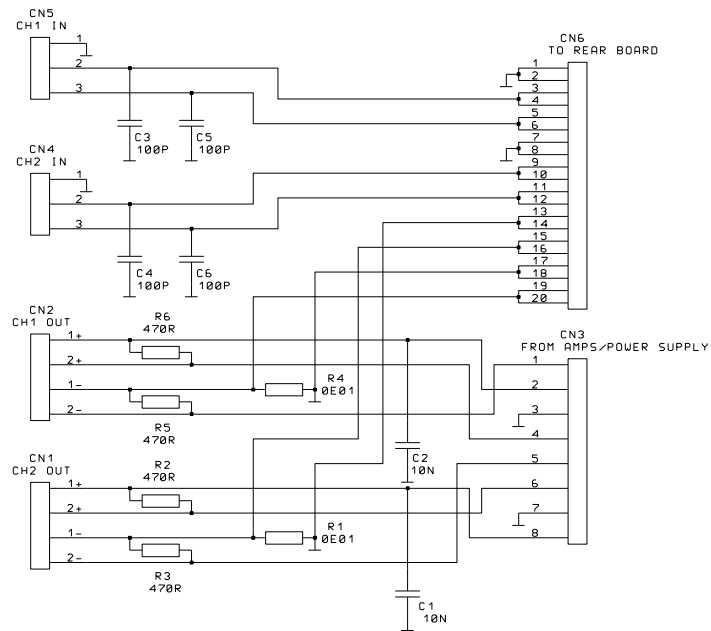



Stage Accompany bv  
Hoorn  
The Netherlands

Project : SSA100/SSA200  
Print : Connector board  
PCB no. : 1085.2003S  
Date : 03-04-2001  
Drawn : J.M. Fortanier

1 page

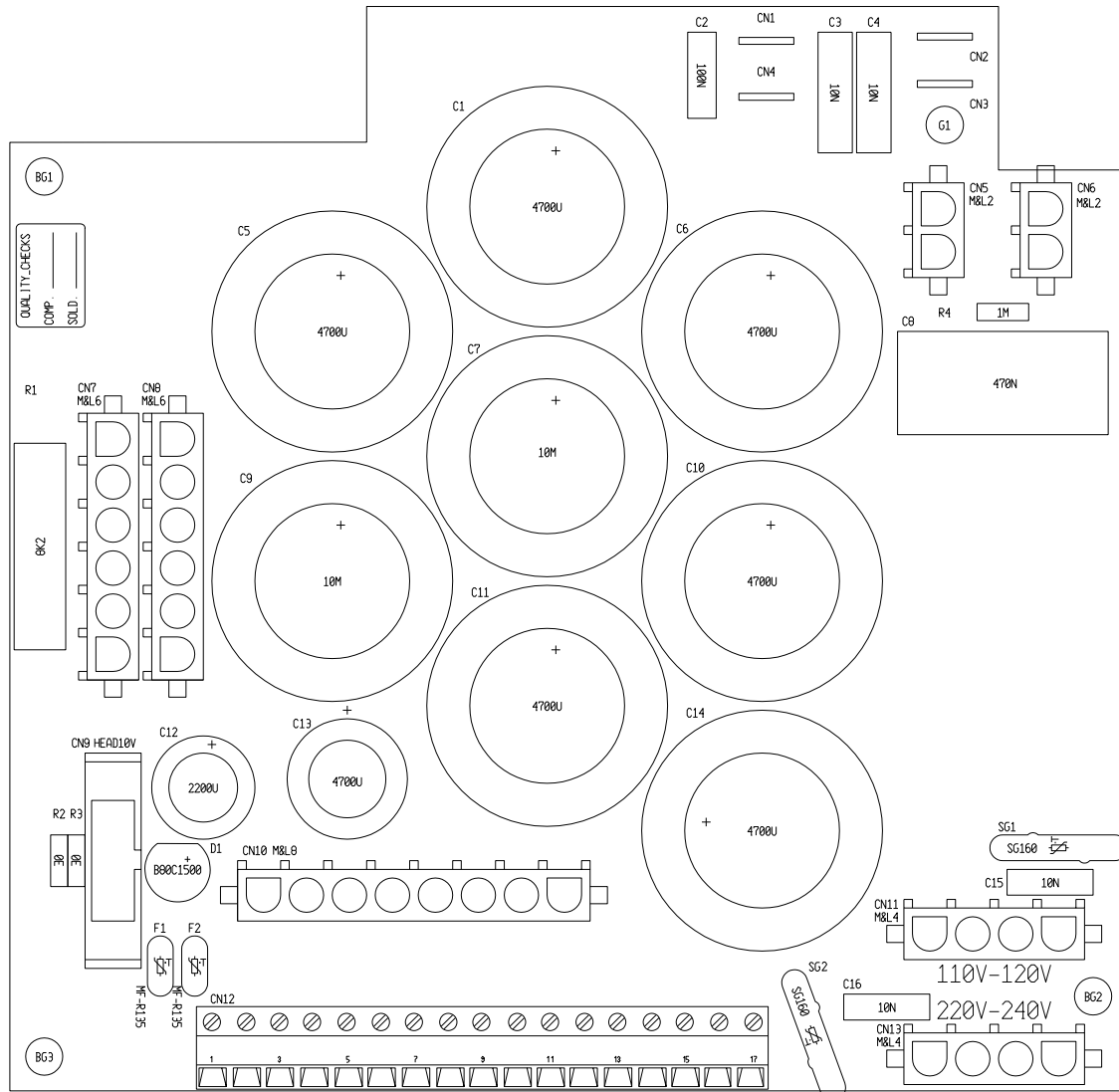
Revision : 0



	Stage Accompany bv Hoorn The Netherlands
	Project : SSA100 Print : Power supply board PCB no. : 1085.2006/3 Date : 02-11-2001 Drawn : J.M. Fortanier
1 page	Revision : 0





# SERVICE MANUAL SSA100