



SERVICE MANUAL ES20

Stage Accompany ES 20

High Efficiency Power Amplifier

Service Manual

April 2002
Revision 6





SERVICE MANUAL ES20

CONTENTS

1	SAFETY AND WARRANTY	2
	1.1 SAFETY	2
	1.2 WARRANTY	2
2	TAKING THE ES20 APART	4
3	BASIC OPERATION OF THE ELECTRONICS	5
	3.1 INPUT AND PROTECION CIRCUITRY	5
	3.2 POWER SUPPLY CIRCUIT	5
	3.3 DRIVER BOARD	6
	3.4 POWER AMPLIFIER BOARD	7
4	ADJUSTMENTS	7
5	FINAL TEST AFTER SERVICING	8
6	INSTALLING THE EFN BOARD	9
7	SPECIFICATIONS	10
8	PCB DRAWINGS AND CIRCUIT DIAGRAMS	11

This manual contains confidential information. Any form of duplication is prohibited.



SERVICE MANUAL ES20

1 SAFETY AND WARRANTY

1.1 SAFETY

- Warning

Inside the ES20, AC voltages up to 240V may be present!

- Connection to the mains voltage

The ES20 chassis is connected to ground by the grounding conductor in the power cord. To avoid electrical shock, plug the power chord into a properly wired receptacle. When this ground connector is not present or interrupted, all accessible parts of the amplifier can cause an electrical shock.

- Fuses

To avoid fire hazard, only replace with fuses of the same type and value.

- Servicing

Do not perform internal service or adjustments unless there is another person present capable of rendering first aid and reanimation. Try to perform all service work with mains power off. Remove mains plug to be sure that there are no internal voltages present.

1.2 WARRANTY

- Summary

New Stage Accompany B.V. warrants to the original commercial purchaser of each new Stage Accompany product, from the date of purchase by the original purchaser until the end of the warranty period, that the product is free of defects in materials or workmanship.

- Warranty period

The warranty period on all Stage Accompany products is five years from the date of the first consumer purchase, with the exception off:

- all electrical products: three years from the date of the first consumer purchase;
- cone assemblies in the loudspeaker and diaphragms in the Compact Drivers: one year from the date of the first consumer purchase;
- movable parts, such as castors, locks, handles, hinges, fans etc. one year from the date of the first consumer purchase;
- computers and associated peripherals: six months from the date of the first consumer purchase.

- How to validate the warranty

To validate warranty, the purchaser must always keep the original receipt of purchase to establish the date of purchase.

- Items excluded from warranty

Appeal on warranty will be avoided in case:

- of defects caused by influence from the outside, accident, misuse, neglect or influence of water;
- the serial number on the warranty and/or product has been defaced, altered or removed;
- of damage due to shipment;
- of damage resulting from neglecting instructions listed in the user manual;
- of damage caused by incorrect, abnormal handling or abuse during delivery;
- the unit has been repaired (or shows signs of repair) by someone not authorised by New Stage Accompany B.V.;
- the original receipt of purchase cannot be presented whenever warranty service is required;
- the cause of damage is unknown.



SERVICE MANUAL ES20

- What we will do

Shipment of the product to an authorised Stage Accompany service center is at the risk and responsibility of the customer. New Stage Accompany B.V. will pay for all labour and material expenses for all repairs covered by the warranty. New Stage Accompany B.V. will not pay for the costs of shipment to the service center or factory. However, New Stage Accompany B.V. will pay for the costs of return shipment to the customer if repairs are covered by warranty.

- Caution

Warranty work can only be performed at authorised Stage Accompany service centres or at the Stage Accompany factory. Every repair or attempted repair by a non-authorised party will void the warranty.

New Stage Accompany B.V. reserves the right to alter specifications without prior notice.

2 TAKING THE ES20 APART

The ES20 can be taken apart in the following way:

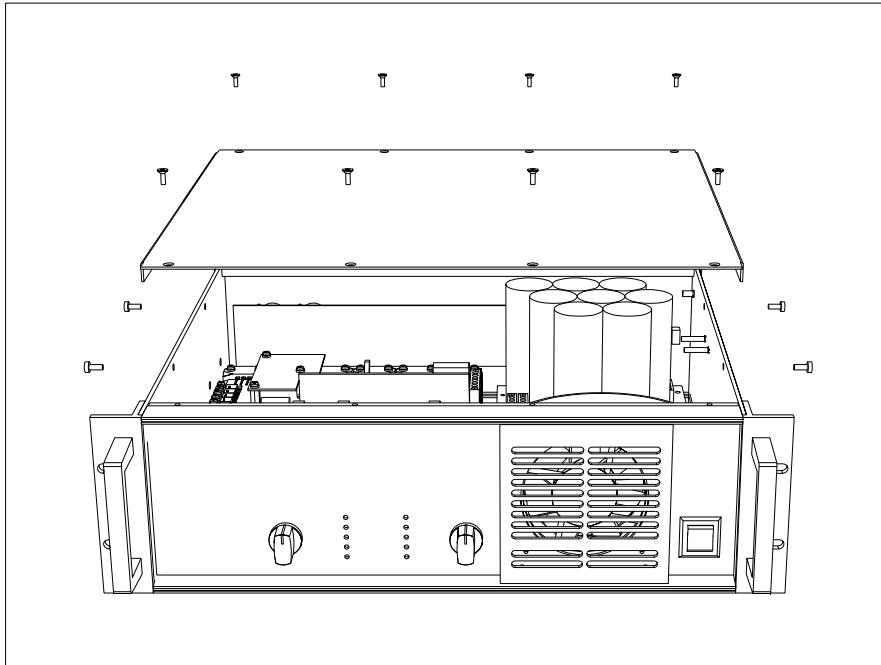

fig 2.1 Removing the lid.

Access to the electronics can be obtained by removing the top panel. Remove the eight screws at the top and the two screws on both the left and right side of the amplifier. Then carefully lift the top panel and disconnect the ground wire attached to the top panel at the inside of the amplifier.

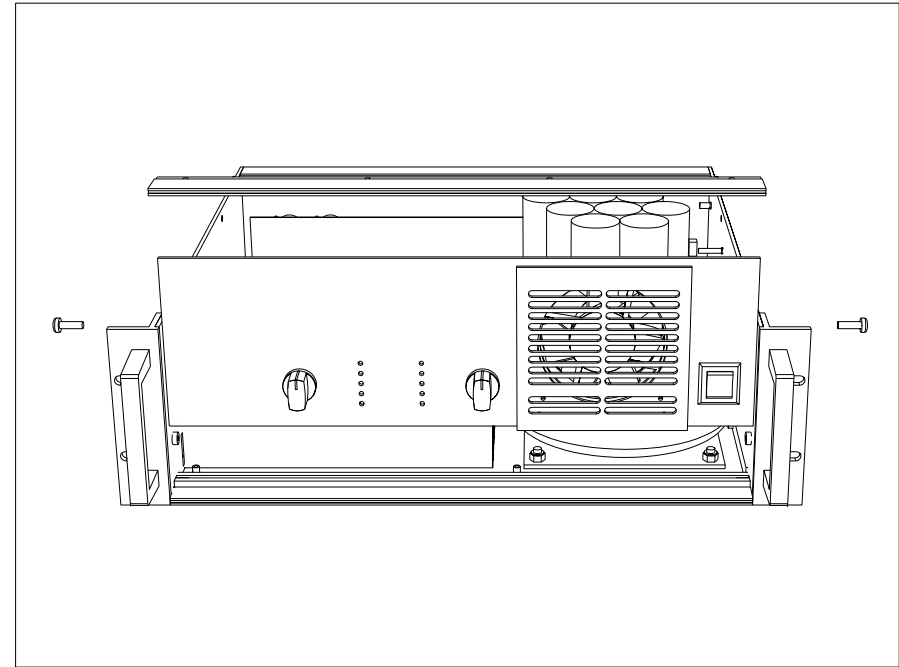

fig 2.2 Removing the frontpanel.

To obtain access to the frontboard, remove the bar on top of the frontpanel by removing one screw on both the left and right side of the amplifier. After removing five connectors from the front board (all connectors except for the fan connector) and disconnecting the mains switch, the frontpanel can be taken out.

The rearpanel can be removed in a similar way, however, for most servicing work, this panel does not need to be removed.



3 BASIC OPERATION OF THE ELECTRONICS

3.1 INPUT AND PROTECTION CIRCUITRY

The front board contains the electronics for the input amplifier and protection circuitry

The front board circuitry contains:

- Signal present indication
- Amplifier level setting
- Thermal protection
- Fan speed control
- DC protection
- Clip indication

The input amplifier is a dedicated differential line receiver. After the debalancing stage, the input signal can be attenuated by conductive plastic potentiometers. The signal is also fed to a network that detects the presence of input signal. A LED on the frontpanel will light if the input signal exceeds -35 dBu, regardless the setting of the input attenuators. For protection purposes, each channel can be muted by a relay (RL1 and RL2).

The thermal protection senses the temperature of each power amplifier as well as the mains transformer. IC4d determines the appropriate fan speed. IC5a and IC5b compare the measured temperatures to the programmed limits and activate the input mute relays and front board LED's if necessary. The amplifier limit is 90 °C and the transformer limit is 100 °C. The amplifiers are unmuted when the temperatures have dropped 5 degrees. A power amplifier thermal overload only mutes the related channel. A transformer thermal overload mutes both channels.

The DC protection senses the amplifier outputs for DC and very low frequency components. The output relay (located on the amplifier board) is muted when more than 3V DC (positive or negative) is detected. This circuit also provides a turn on delay for the output relays and a turn on delay for

the input mute relays. When DC is detected, a LED will light on the amplifier's front panel.

Clipping of the amplifiers is detected by the circuits around IC10a and IC10b. When the output of the amplifier is within the region of 0.5 dB to actual clipping, this is indicated by a LED on the frontpanel of the amplifier.

3.2 POWER SUPPLY CIRCUIT

The power supply board contains all the electronics for rectifying and filtering 6 different supply voltages. ± 110 V and ± 55 V voltages feed the power amplifiers and ± 24 V supplies feed the front board and the DDC circuits. Inrush current reduction is obtained by NTCs SG1 and SG2. The ES20 can internally be set to 110-120 V or 220-240 V operation. The voltage range is determined by CN11 and CN13. The correct settings are:

110-120 V : mains switch connector in CN11, jumper connector in CN13

220-240 V : mains switch connector in CN13, jumper connector in CN11

Note that the ± 24 V voltages are protected by multifuses (F1 and F2). These devices normally have very low impedance. In case of a current overload the impedance rises to a high value, simulating a blown fuse. When this happens, turn off the amplifier and perform the needed repair. The multifuses reset automatically and do not need to be replaced.

3.3 DRIVER BOARD

The driver boards contain the preamplifiers of the ES20. The basic electronics are shown in figure 3.1.

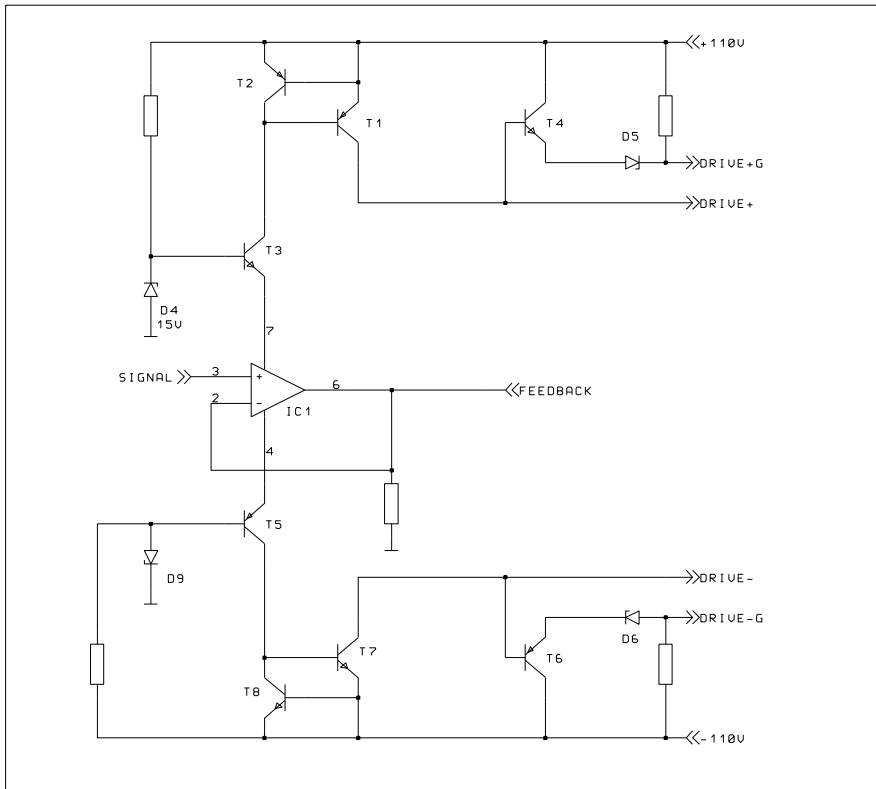

Figure 3.1 ES20 preamplifier set-up.

The input signal is fed to a conventional opamp (IC1). The output current from IC1 is taken from its power supply pins and fed to the emitters of a pair of common base cascode transistors (T3 and T5) that provide

regulated DC voltages for the opamp. The output currents from the input buffer are fed to two current mirrors (T1/T2 and T7/T8), into the transimpedance gain stage. It is here that the high output voltage is generated. The half wave rectification action of IC1's output current causes the two current mirrors to receive complementary input currents. When IC1 is sourcing output current, it causes a corresponding increase in the current of the upper mirror and a decrease in that of the lower mirror. This forces the voltage at the output of the transimpedance stage to swing positive. For cases when IC1 is sinking current, exactly the opposite is true. Note that the quiescent supply current of IC1 serves to bias the two current mirrors that sit referenced to each power supply rail, thus providing an appropriate operating point for the transimpedance stage and bias voltage generator (both located on the power amplifier board). Drive currents for the class G output power stage are supplied through T4 and T6. Zener diodes D5 and D6 are a constant voltage source of 6.2 volts that provide the necessary voltage gap for driving the class G current gain amplifier on the power amplifier board.

3.4 POWER AMPLIFIER BOARD

Figure 3.2 shows the basic set-up of the power amplifier.

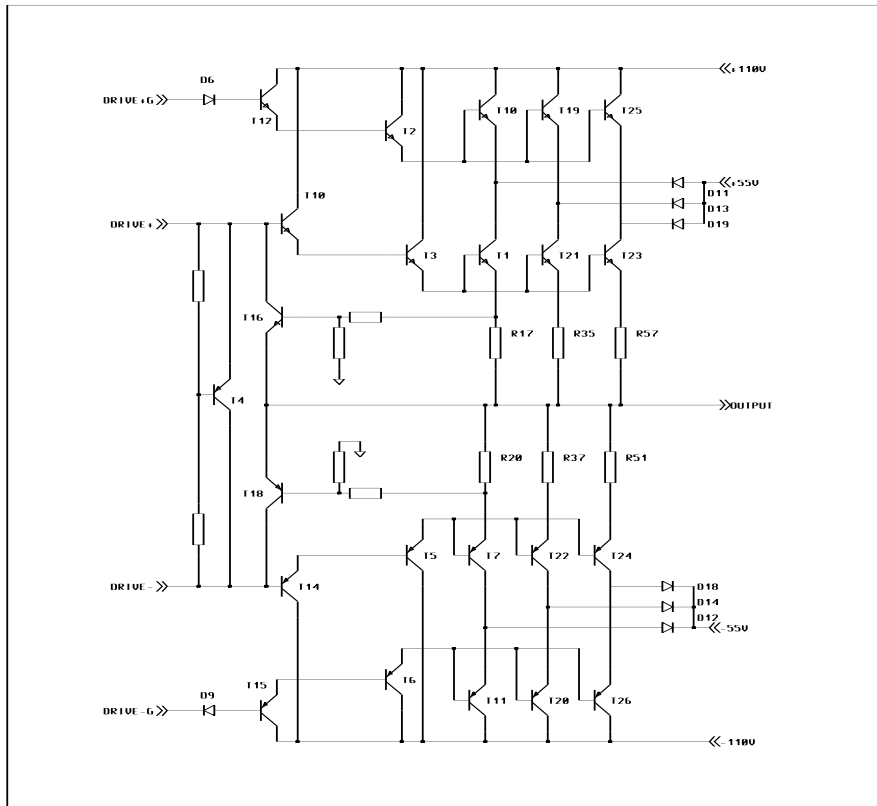

Figure 3.2 ES20 power amplifier set-up.

The driver board circuit provides four signals, drive +, drive -, drive +g and drive -g. The positive drive current (drive +) is boosted by T13 and T3 and fed to the NPN power transistors T1, T21 and T23. The negative drive current (drive -) is boosted by T14 and T5 and fed to the PNP power

transistors T7, T22 and T24. The positive class G drive current (drive +g) is boosted by T12 and T2 and fed to the NPN power transistors T10, T19 and T25. The negative class G drive current (drive -g) is boosted by T15 and T6 and fed to the PNP power transistors T11, T20 and T26. T4 is configured as a constant voltage source and provides the bias current for the amplifier output stage. The amplifier normally operates on the ± 55 V power supplies though diodes D11, D13, D19, D12, D14 and D18. The collectors of T1, T21 and T23 have in this case a constant voltage of +55 V. When the output of the amplifier rises above +50 V the emitter voltages of T10, T19 and T25 will rise linearly with the output voltage taking over the power supply from D11, D13 and D19. Exactly the same is true for the negative side of the amplifier. Dynamic current limiting of the amplifier output stage is handled by T16 and T18. When the current drawn from the amplifier rises, the voltage across R17 and R20 rises too. At the moment that this voltage reaches 0.65 volts, T16 and T18 start conducting drive current away from the output transistors and thus limiting output current. Current limiting depends on the output voltage. At 0 V output the maximum current per transistor is 5.5 A rising to 13 A at 60 V. Overall feedback and DC stability of the amplifier is achieved by the DDC circuit build around opamp IC1.

4 ADJUSTMENTS

After repairs the amplifier's bias current should be checked and readjusted if necessary. The bias current for each transistor pair is approximately 50 mA (± 25 %) at 40 °C. The bias current can be checked by measuring the voltage across one of the 0E33 emitter degradation resistors and can be adjusted with P1. Turning P1 clockwise will increase bias current. Adjust P1 for approximately 15 mV.



SERVICE MANUAL ES20

5 FINAL TEST AFTER SERVICING

For a final test of the amplifier a signal generator and a level/distortion analyser are needed. First check the amplifier's maximum power output. Connect 8 Ohm dummy loads to both outputs and apply a 1 kHz signal to both inputs. The output voltages should at least be 65 Vrms single channel, or 60 Vrms both channels driven (with a correct 230 V mains voltage).

Next check the frequency response. This should be done at an output level of approximately 10 Vrms and an 8 Ohm dummy on both outputs. A typical frequency curve is shown in figure 5.1. The final result should be better than 10 Hz..70 kHz -3 dB.

Next check the total harmonic distortion. The final test specifications are: $U_{out} = 40$ Vrms into 8 or 4 Ohm: THD < 0.2 @10 Hz .. 20 kHz, measured in a 80 kHz bandwidth.

The total noise level of the amplifier should be approximately 110 dB(A) under 60 Vrms output level (-72 dBu). For this test the XLR input connectors are left open.

6 INSTALLING THE EFN BOARD

To install the 'EFN' board, remove the ES20's top panel as is described in chapter 2. Figure 6.1 shows where to insert the EFN circuit board for channel 1. The EFN board 'clicks' into the connector on the amplifier board and does not need to be secured by any screws. To activate the EFN module, jumper J1 on the amplifier board needs to be placed in the position 'EQ CARD' otherwise the EFN modules are bypassed. The installation procedure of the channel 2 EFN module is identical to the installation of the channel 1 module.

For bridge mode operation **two** special bridge mode modules are needed. The standard EFN-DP protection boards are **not** suitable for bridge mode operation!

Attach the grounding wire to its connector attached to the underside of the lid and screw the lid back on. When removing the EFN module(s), move jumper J1 back to its original position, otherwise the signal path to the power amplifier is interrupted and the amplifier will not work!

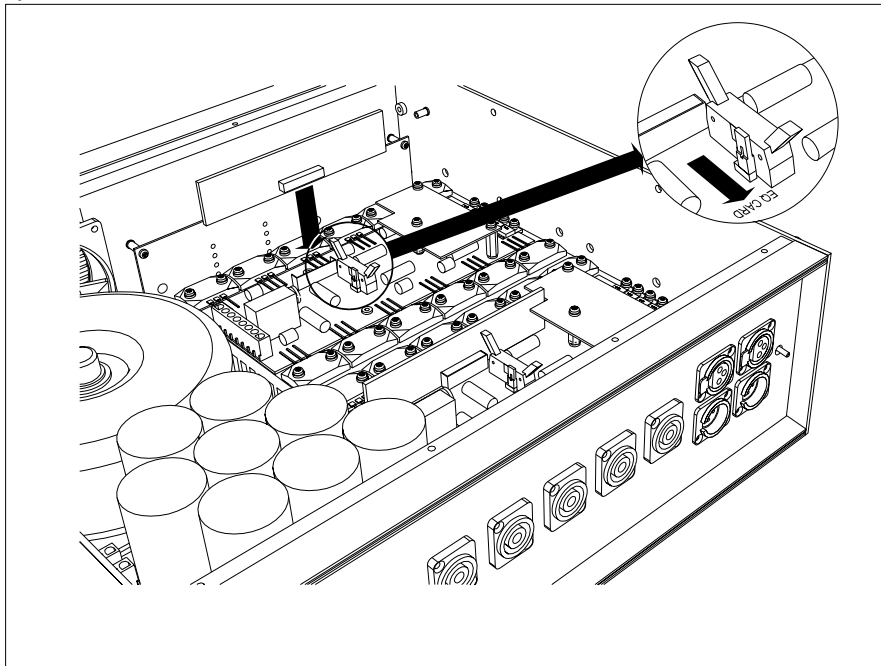

fig 6.1 Installing the EFN board for channel 1.



SERVICE MANUAL ES20

7 SPECIFICATIONS

Input sensitivity	: 1.76 Vrms (+7.1 dBu) for full RMS power into 4 Ohm	Power consumption	: 100 VA (standby) 1400 VA 1/8 of maximum output power pink noise in 2 Ohm
Maximum input level	: +22 dBu	Weight	: 21.6 kg, 48 lb
Input impedance	: 50 kOhm each leg	Housing	: 19 inch rack mount 3 HU, 410 mm (16.1 in) deep behind the mounting surface (without connectors).
Common mode rejection	: > 70 dB @ 20 Hz..20 kHz	Dimensions	: 133 x 482 x 415 mm (h x w x d) (5.25 x 19.0 x 16.3 in) (without connectors)
Frequency range	: @ 100 W into 8 Ohm 10 Hz..20 kHz +0..-0.4 dB 10 Hz..65 kHz +0..-3 dB		
Gain	: 30 dB (31.6x)		
Channel separation	: > 75 dB @ 1kHz, 100 W into 8 Ohm > 60 dB @ 20 kHz, 100 W into 8 Ohm		
Total harmonic distortion	: < 0.2 % @ 20 Hz..20 kHz, more than 2 Ohm load at all powers 1 dB below clipping < 0.01 % @ 1 kHz, 100 W into 8 Ohm < 0.1 % @ 20 kHz, 100 W into 8 Ohm		
Intermodulation distortion	: @ 100 W into 8 Ohm < 0.1 % @ 200 Hz..10 kHz < 0.3 % @ 10 kHz..20 kHz		
Signal to noise ratio	: > 110 dB A-weighted		
Slew rate	: > 40 V/μs		
Damping factor	: 10.000 @ 1 kHz, 8 Ohm		
Output power	: RMS / Peak @ 1 kHz, 1 % THD 2 x 500 / 610 W @ 8 Ohm 2 x 770 / 1000 W @ 4 Ohm 2 x 960 / 1400 W @ 2 Ohm		
Output power bridged	: RMS / Peak @ 1 kHz, 1 % THD 1 x 1000 / 1220 W @ 16 Ohm 1 x 1540 / 2000 W @ 8 Ohm 1 x 1920 / 2800 W @ 4 Ohm		
Mains supply voltage	: Stated at rear of amplifier		



stage accompany

SERVICE MANUAL ES20

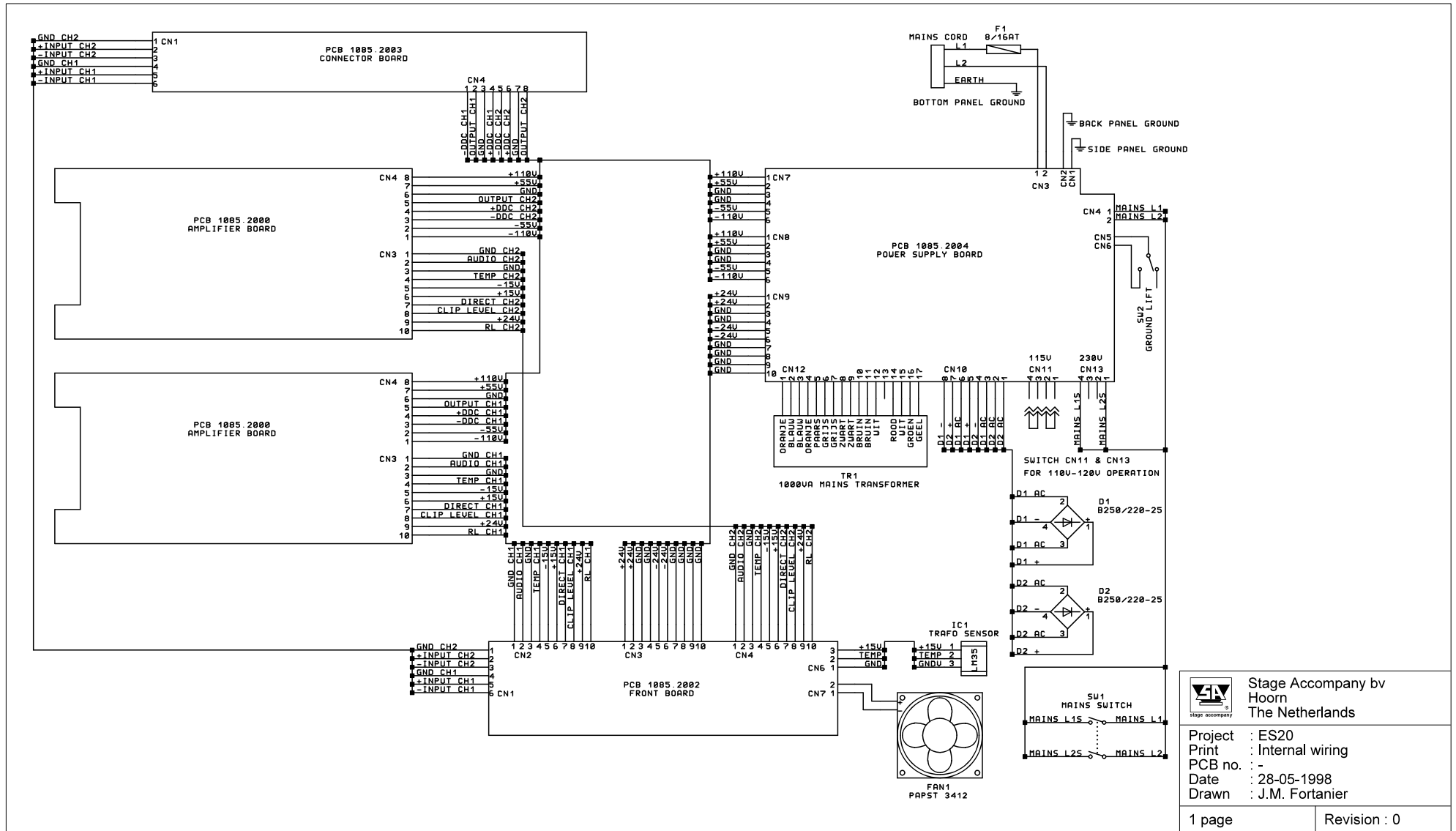

Stage Accompany bv Hoorn The Netherlands	
Project	: ES20
Print	: Internal wiring
PCB no.	: -
Date	: 28-05-1998
Drawn	: J.M. Fortanier
1 page	Revision : 0

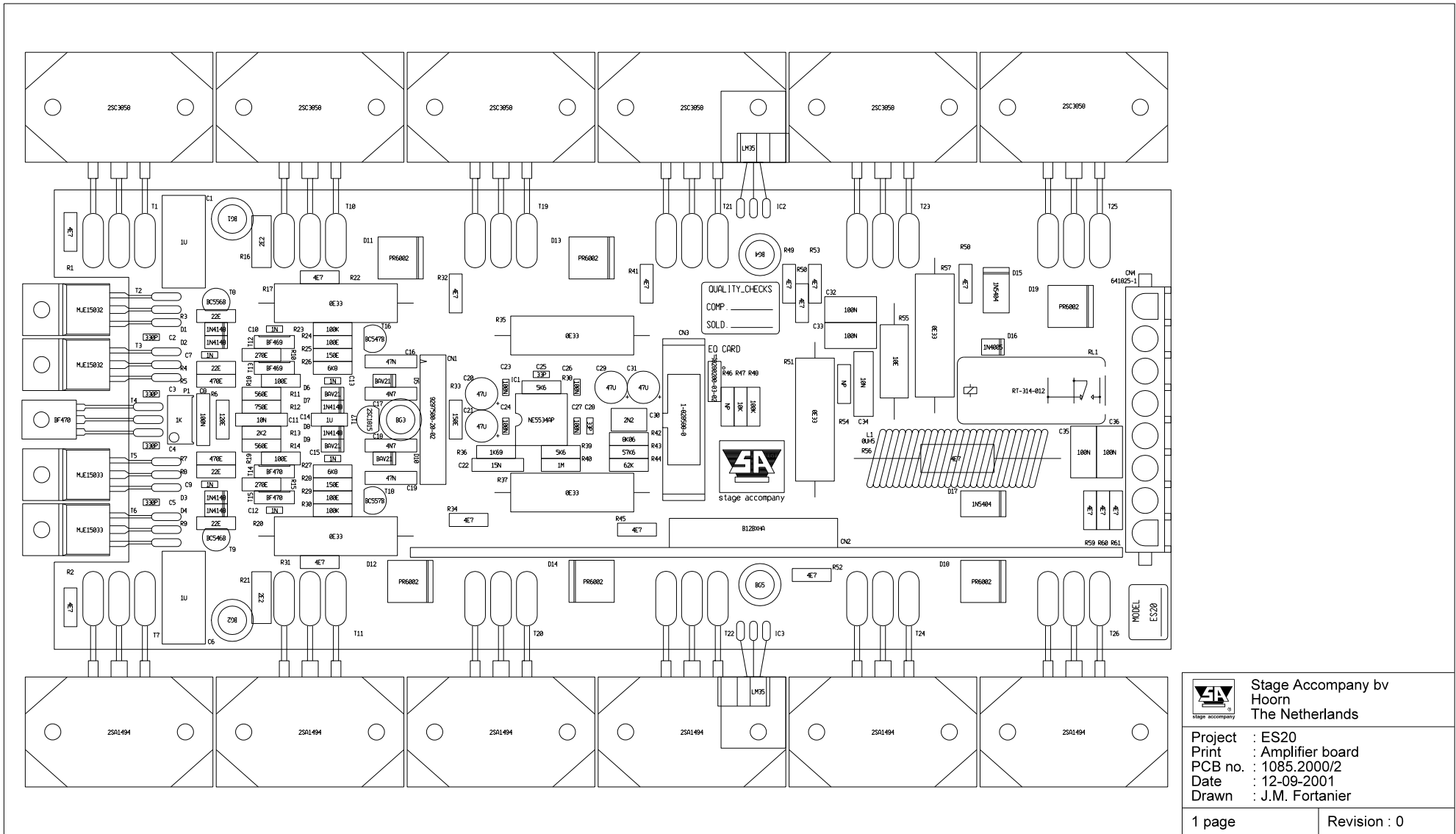

Stage Accompany by
Horn
The Netherlands

Project : ES20
Print : Amplifier board
PCB no. : 1085.2000/2
Date : 12-09-2001
Drawn : J.M. Fortanier

1 page

Revision : 0

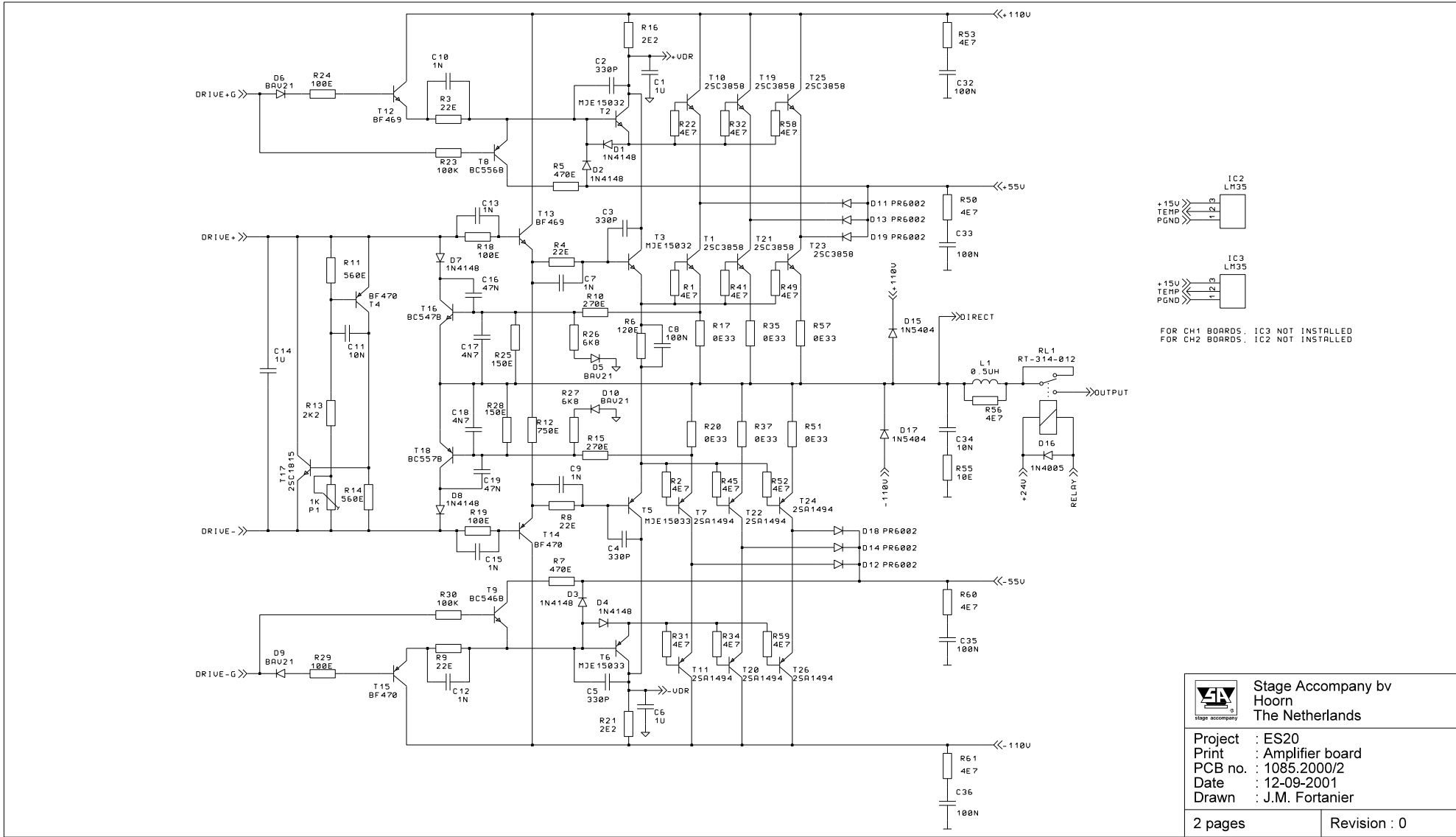

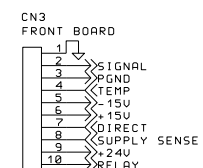
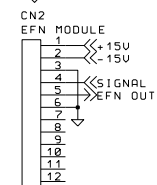
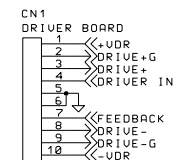
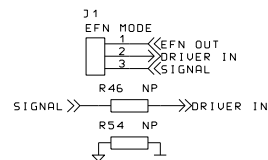
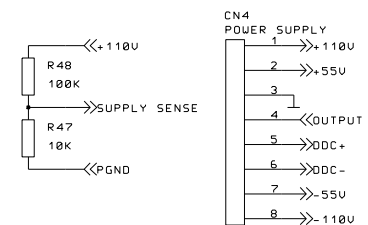
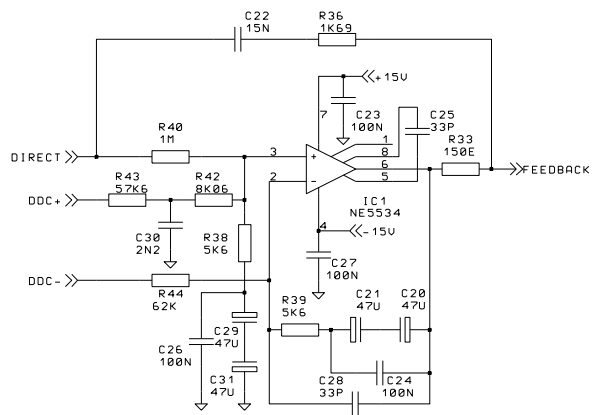

 <small>stage accompany</small>	Stage Accompany bv Hoorn The Netherlands
	Project : ES20 Print : Amplifier board PCB no. : 1085.2000/2 Date : 12-09-2001 Drawn : J.M. Fortanier
2 pages	Revision : 0



stage accompany

SERVICE MANUAL ES20

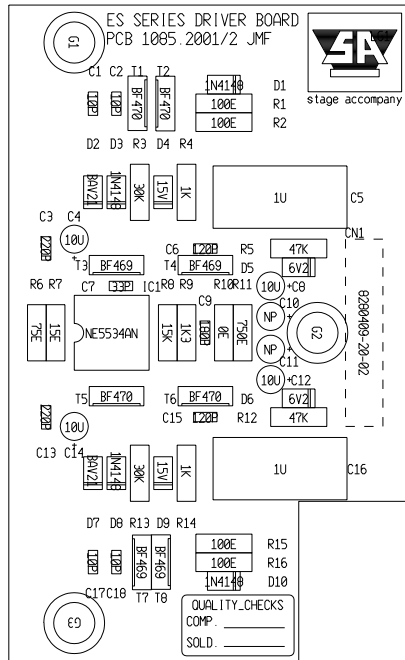

Stage Accompany bv
Hoorn
The Netherlands

Project : ES10/20
Print : Driver board
PCB no. : 1085.2001/2
Date : 02-11-2001
Drawn : J.M. Fortanier

1 page

Revision : 0

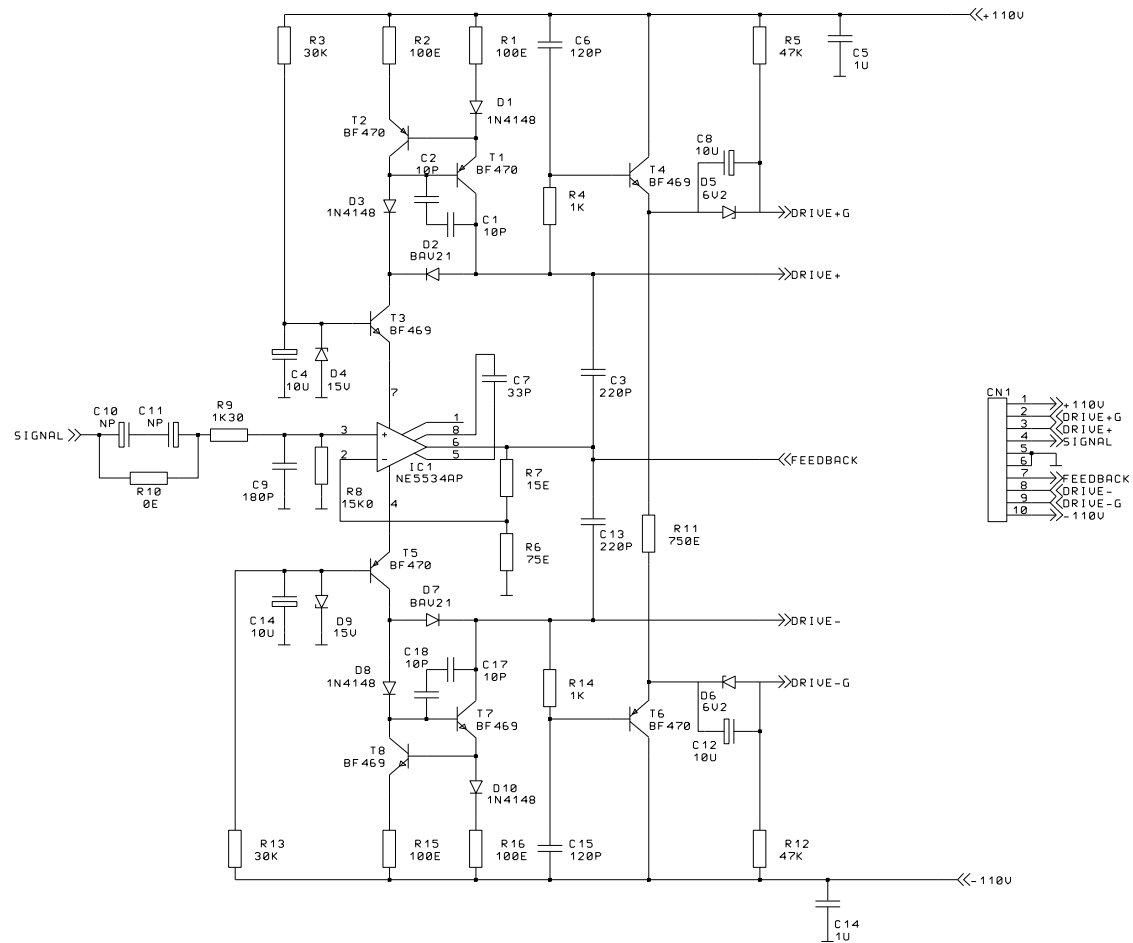



 Stage Accompany bv
Hoorn
The Netherlands

Project : ES10/20
Print : Driver board
PCB no. : 1085.2001/2
Date : 25-04-2002
Drawn : J.M. Fortanier

1 page

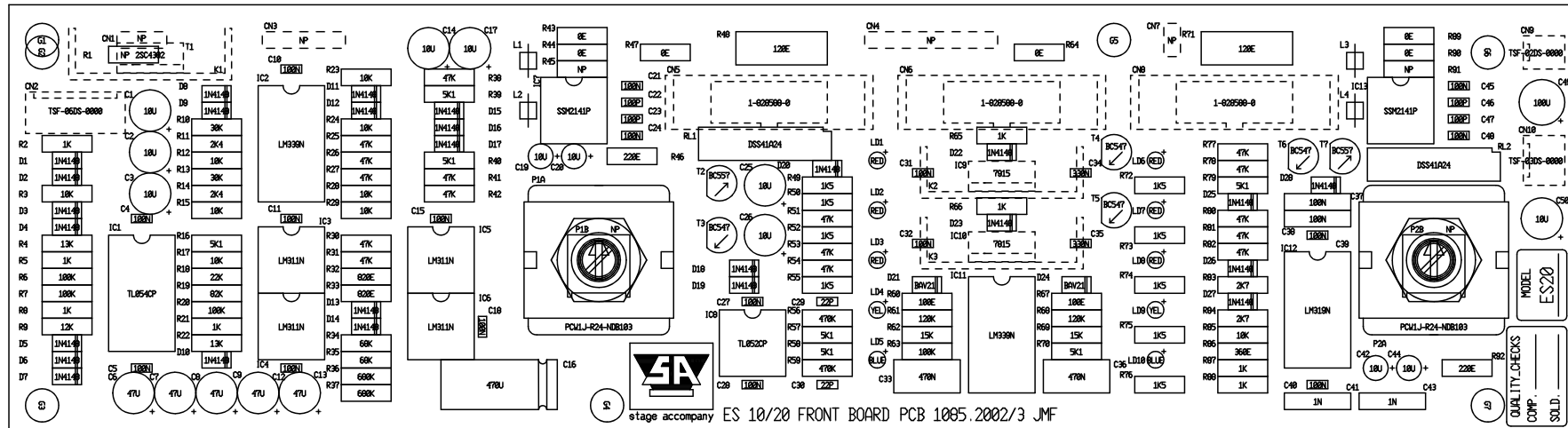
Revision : 0



		Stage Accompany by Hoorn The Netherlands
Project	: ES20	
Print	: Front board	
PCB no.	: 1085.2002/3	
Date	: 20-10-2000	
Drawn	: J.M. Fortanier	
1 page	Revision : 0	

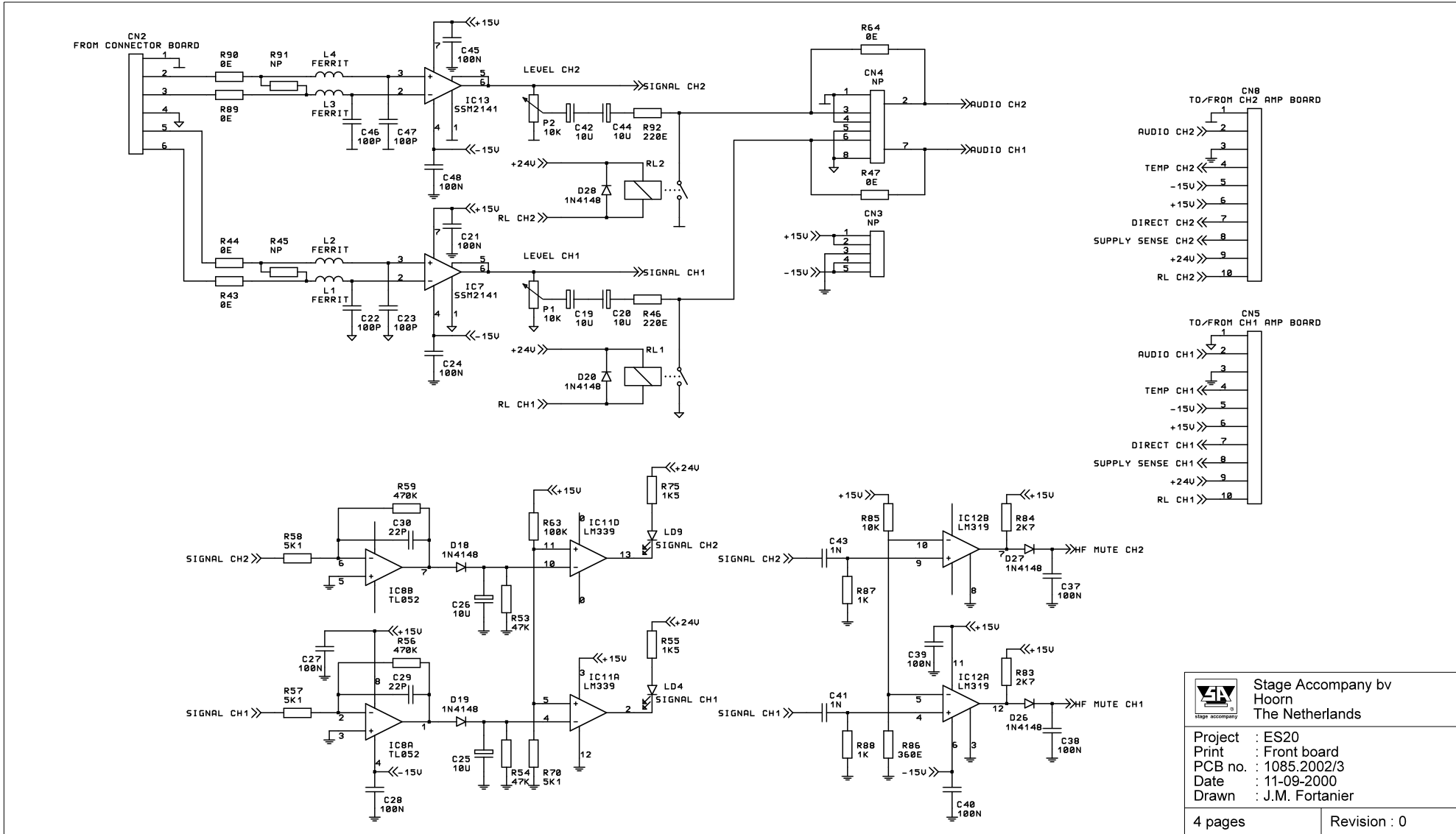

		Stage accompany by	
		Hoor	
Project : ES20		The Netherlands	
Print : Front board			
PCB no. : 1085.2002/3			
Date : 11-09-2000			
Drawn : J.M. Fortanier			
4 pages	Revision : 0		

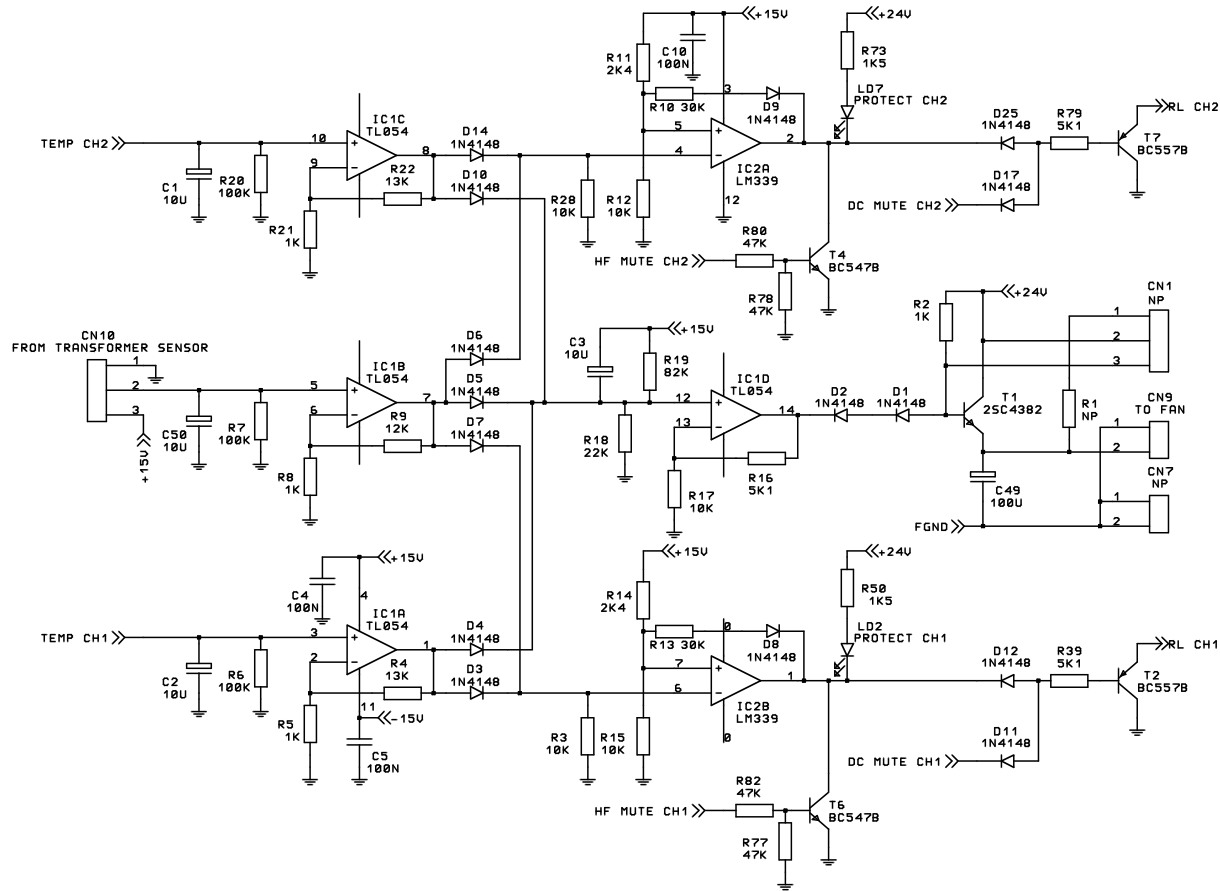



 Stage Accompany bv
 Hoorn
 The Netherlands

Project : ES20
 Print : Front board
 PCB no. : 1085.2002/3
 Date : 11-09-2000
 Drawn : J.M. Fortanier

4 pages

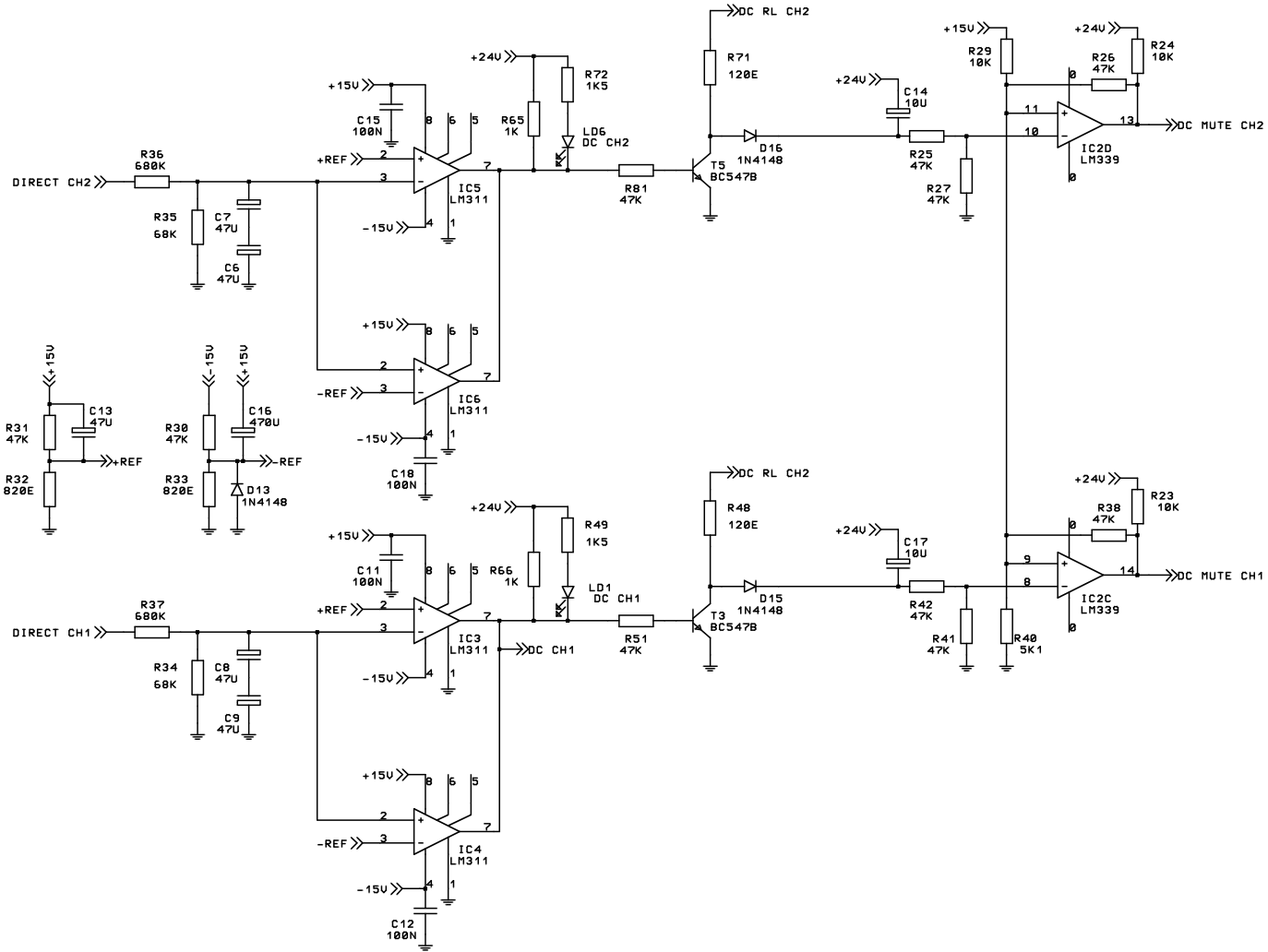
Revision : 0



	Stage Accompany bv Hoorn The Netherlands
	Project : ES20 Print : Front board PCB no. : 1085.2002/3 Date : 11-09-2000 Drawn : J.M. Fortanier
4 pages	Revision : 0

SERVICE MANUAL ES20

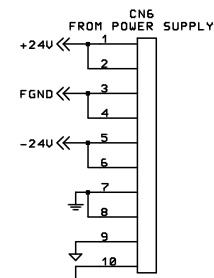
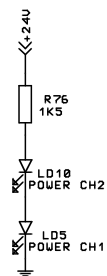
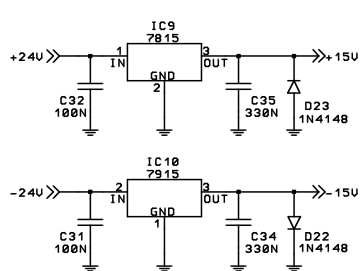
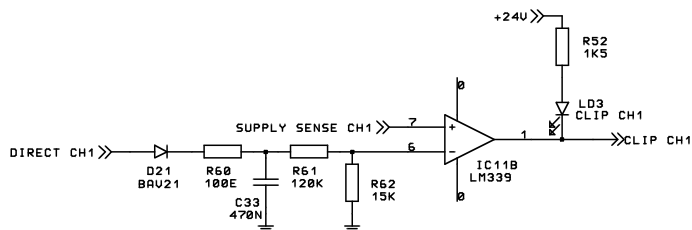
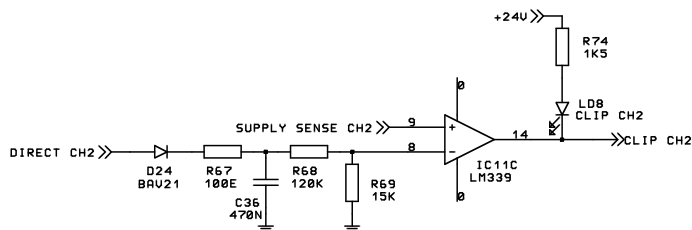

	Stage Accompany bv Hoorn The Netherlands
	Project : ES20 Print : Front board PCB no. : 1085.2002/3 Date : 11-09-2000 Drawn : J.M. Fortanier
4 pages	Revision : 0

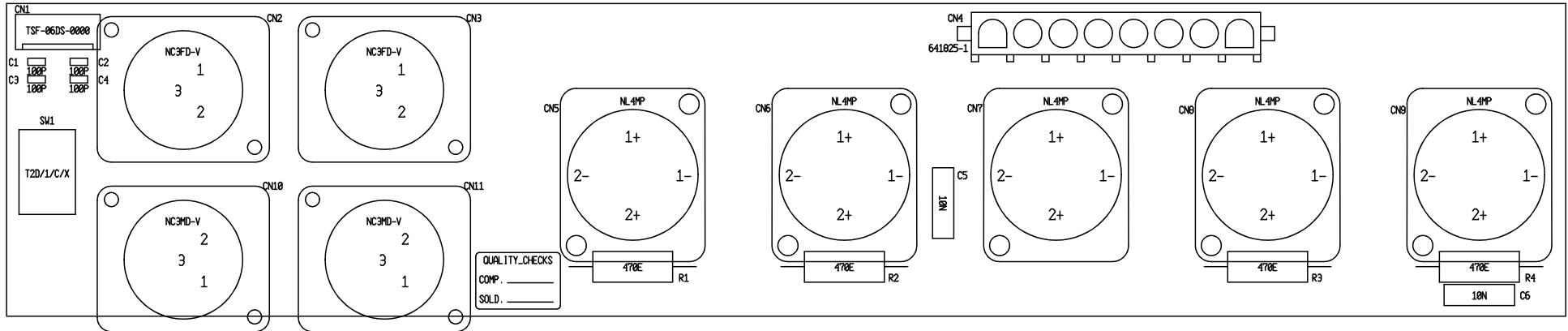



Stage Accompany bv
 Hoorn
 The Netherlands

Project : ES10/20
 Print : Connector board
 PCB no. : 1085.2003
 Date : 08-04-1998
 Drawn : J.M. Fortanier

1 page

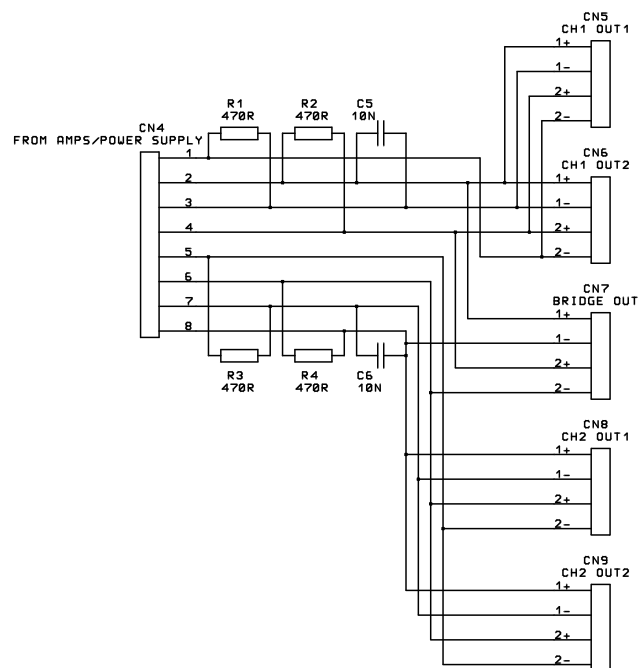
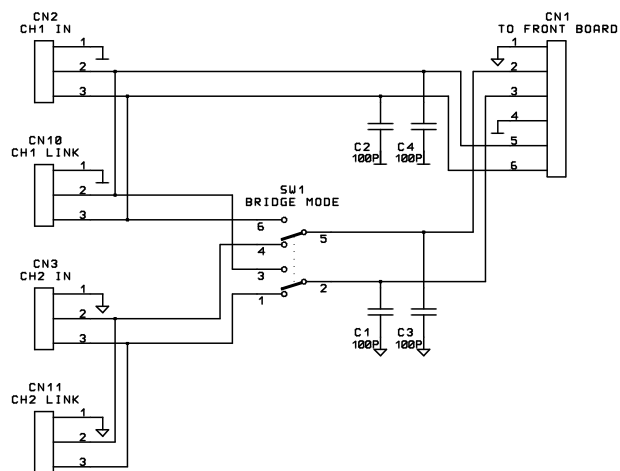
Revision : 0



	Stage Accompany bv Hoorn The Netherlands
	Project : ES10/20 Print : Connector board PCB no. : 1085.2003 Date : 08-04-1998 Drawn : J.M. Fortanier
1 page	Revision : 0

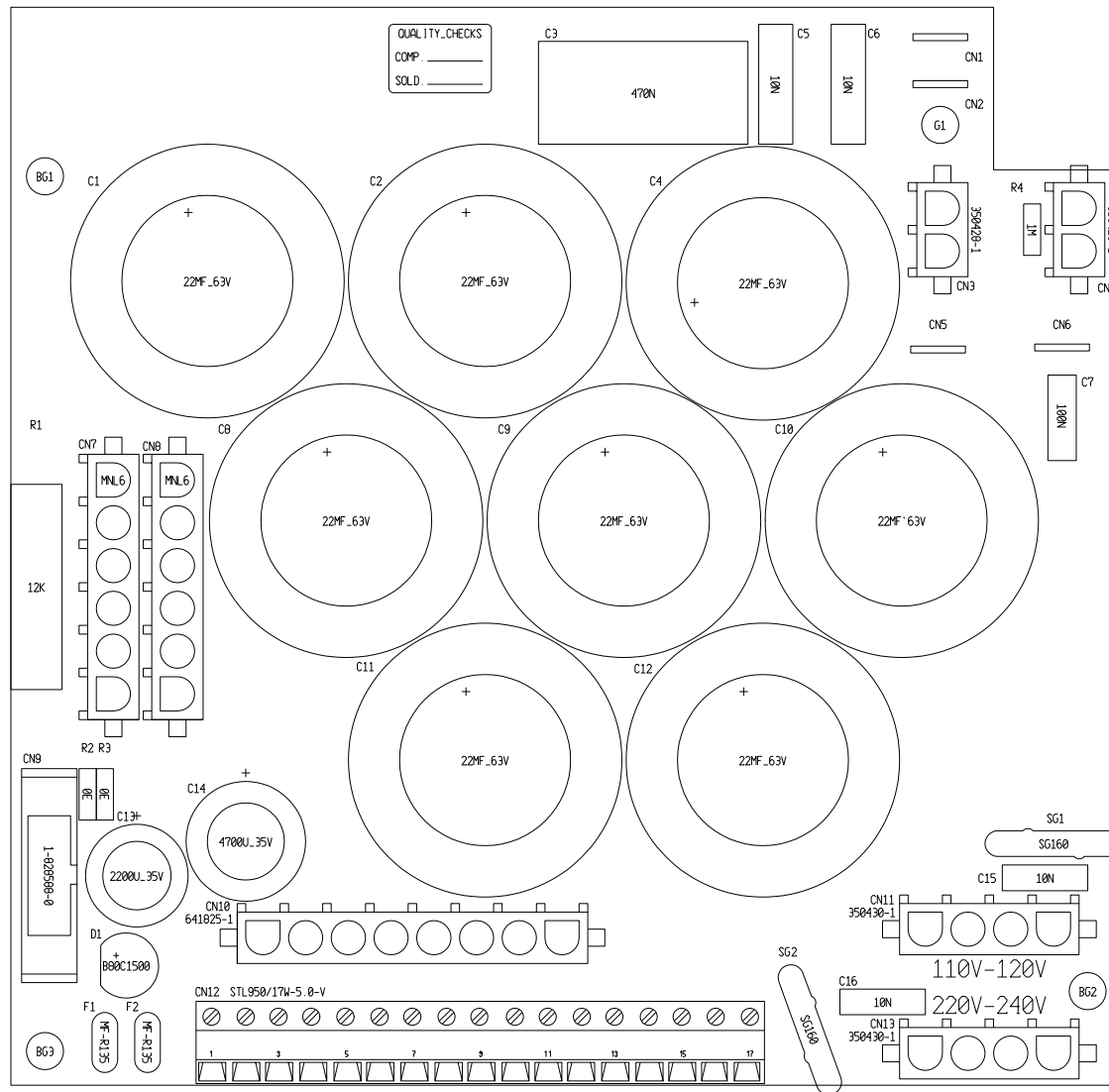

 Stage Accompany bv Hoorn The Netherlands	
Project : ES20 Print : Power supply board PCB no. : 1085.2004/3 Date : 12-09-2001 Drawn : J.M. Fortanier	
1 page	Revision : 0

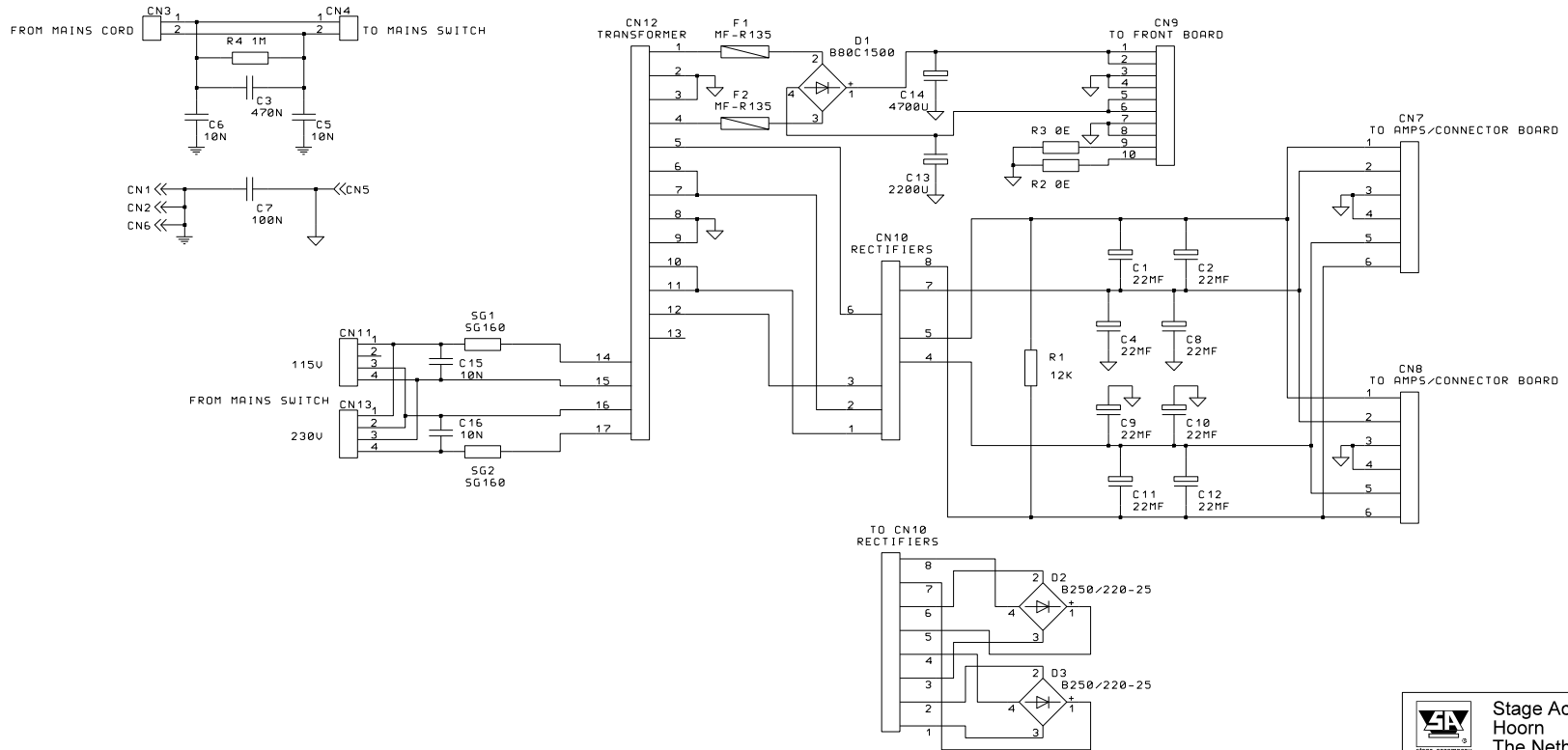

Stage Accompany bv
Hoorn
The Netherlands

Project : ES20
Print : Power supply board
PCB no. : 1085.2004/3
Date : 12-09-2001
Drawn : J.M. Fortanier

1 page

Revision : 0



stage accompany

SERVICE MANUAL ES20